

SERVICE MANUAL

THE QUALITY OF
THIS MANUAL IS
THE BEST THAT
IS AVAILABLE

For Service Manuals Contact
MAURITRON TECHNICAL SERVICES
8 Cherry Tree Rd, Chinnor
Oxon OX9 4QY
Tel:- 01844-351694 Fax:- 01844-352554
Email:- enquiries@mauritron.co.uk

CA-2010

INTEGRATED AMPLIFIER

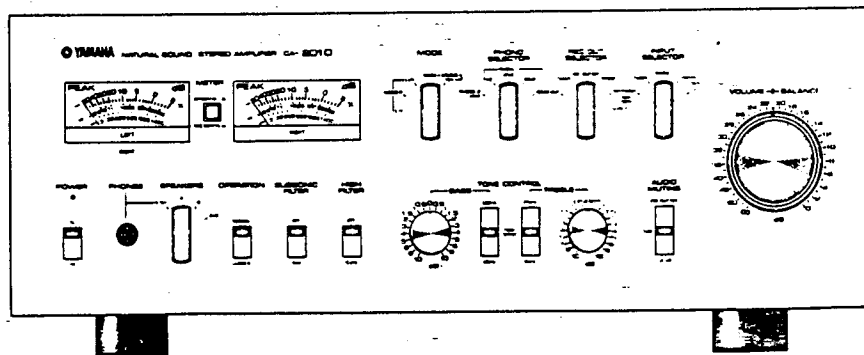

SINCE 1887



YAMAHA

CONTENTS

SPECIFICATIONS	2
EXTERNAL VIEW	
FRONT PANEL	4
REAR PANEL (GENERAL MODEL)	4
REAR PANEL (EUROPEAN MODEL)	4
INTERNAL VIEW	
TOP VIEW	6
BOTTOM VIEW	6
PARTIAL DISASSEMBLY	7
ADJUSTMENT	11
PRINTED CIRCUIT BOARD	
FUNCTION CIRCUIT BOARD	13
TONE CONTROL CIRCUIT BOARD	15
METER CIRCUIT BOARD	17
COUPLER CIRCUIT BOARD	18
LAMP CIRCUIT BOARD	18
ELECTROLYTIC CAPACITOR CIRCUIT BOARD	18
MAIN CIRCUIT BOARD	19
POWER SUPPLY CIRCUIT BOARD	20
BLOCK DIAGRAM	21
PARTIAL CHANGES MADE ACCORDING TO DESTINATION	22
OVERALL SCHEMATIC DIAGRAM	23
WIRING	25

SPECIFICATIONS

INPUT SENSITIVITY / IMPEADANCE / MAX.INPUT CAP

INPUT TERMINAL	SENSITIVITY	IMPEADANCE	MAXIMAM INPUT CAPACITY
PHONO 1	2mV	47,68,100K Ω	310mV (1KHz, 0.02%)
PHONO 2	2mV	47K Ω	310mV (1KHz, 0.02%)
MC	50 μ V	10 Ω	7.5mV (1KHz, 0.02%)
TUNER,AUX	120mV	50K Ω	20V (1KHz, 0.02%)
MAIN IN	1V	50K Ω	

OUTPUT LEVEL / IMPEADANCE / MAX OUTPUT LEVEL

OUTPUT TERMINAL	OUTPUT LEVEL	IMPEADANCE	MAXUMUM OUTPUT LEVEL
REC OUT	120mV	600 Ω	18.6V (1KHz, 0.02%)
PRE OUT	1V	500 Ω	7V (1KHz, 0.02%)

FREQUENCY RESPONCE

	FREQUENCY	RATING
PHONO 1,2, MC	30 ~ 15KHz	0 \pm 0.2dB (Deviation from R1AA)
TUNER \rightarrow PRE OUT	5 ~ 100KHz	0 \pm ₁ ⁰ dB
TUNER \rightarrow SP OUT	5 ~ 50KHz	0 \pm ₁ ⁰ dB (8 Ω road)

TONE CONTROL

	TURN OVER FREQUENCY	RATING
BASS	125Hz 500Hz	20Hz \pm 10dB
TARBLE	8KHz 2.5KHz	20KHz \pm 10dB

For Service Manuals Contact
MAURITRON TECHNICAL SERVICES
 8 Cherry Tree Rd, Chinnor
 Oxon OX9 4QY
 Tel:- 01844-351694 Fax:- 01844-352554
 Email:- enquiries@mauritron.co.uk

FILTER

	fc	RATING
SUBBSNIC	fc=15Hz	-12dB / OCT
HIGH	fc=10KHz	-12dB / OCT

NOISE LEVEL, S/N

	RATING
PHONO 1,2	82dB (IHF A NETWORK)
MC	71dB (IHF A NETWORK) INPUT 50 Ω short
	68dB (IHF A NETWORK) INPUT 0 Ω short
TUNER,AUX,TAPE	100dB (IHF A NETWORK)
MAIN	118dB (IHF A NETWORK)
RESIDUAL NOISE	70 μ V

DISTORTION

	CONDITONS	RATING
PHONO 1.2	REC OUT 5V, 20 ~ 20KHz	Less than 0.003%
MC	REC OUT 3V, 20 ~ 20KHz	Less than 0.03%
TUNER, AUX	PRE OUT 3V, 20 ~ 20KHz	Less than 0.005%
MAIN IN	SP OUT 60W / 8Ω 20~20KHz (CLASS B)	Less than 0.01%
	SP OUT 15W / 8Ω 20~20KHz (CLASS A)	Less than 0.005%
TUNER→SP OUT PHONO→SP OUT	NDCR SP OUT 60W / 8Ω 20~20KHz (CLASS B)	Less than 0.01%
DISTORTION- POWER RANGE	VOL-20 dB, 0.1W~ 120W/8Ω	0.1%
	VOL-40 dB, 4mW~ 120W/8Ω	0.1%

OUTPUT

	CONDITIIS	RATING
AUX IN→SP OUT	8Ω, CLASS B, 120W+120W, 20 ~ 20KHz	0.03%
	130W+130W, 1KHz	0.03%
	4Ω, CLASS B, 140W+140W, 20 ~ 20KHz	0.03%
	180W+180W, 1KHz	0.03%
	8Ω CLASS A, 30W+30W, 20 ~ 20KHz	0.03%

POWER BANDWIDTH

	FREQUENCY	RATING
8Ω, CLASS B	10Hz ~ 50KHz	0.03%
8Ω, CLASS A	10Hz ~ 70KHz	0.03%

DAMPING FACTOR

	DAMPING FACTOR
1KHz, 8Ω	45

LEVEL METER

INDICATION RANGE	-50dB~+5dB (1mW~316W)
RESPONCE TIME	100μs
DECAY TIME	0.95 sec

OTHERS

DIMENSIONS	461 x 360 x 170 mm (18-1/4" x 14-1/4" x 6-3/4")
WEIGHT	21 kg(46.2 lbs)
POWER SOURCE	AC 110-240V, 50 / 60Hz
POWER CONSUMPTION	U.S. & CANADIAN MODELS : 600W,700VA EUROPIAN MODEL:900W

EXTERNAL VIEW

FRONT PANEL

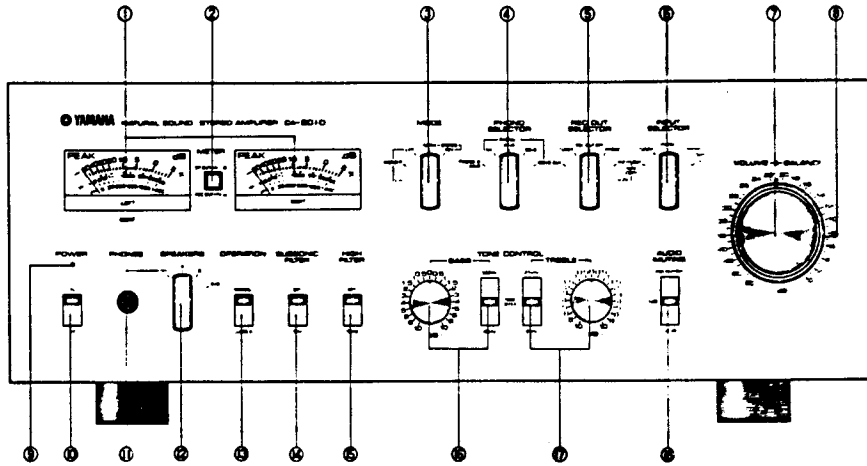

REAR PANEL (GENERAL MODEL)

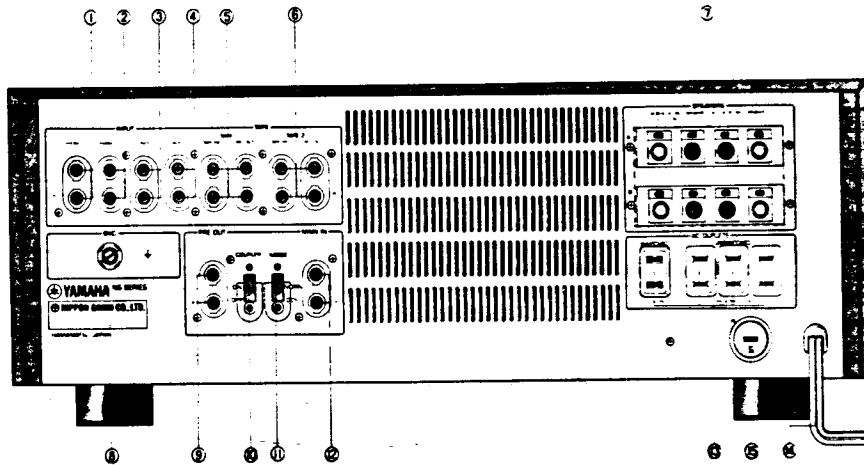

REAR PANEL (EUROPEAN MODEL)

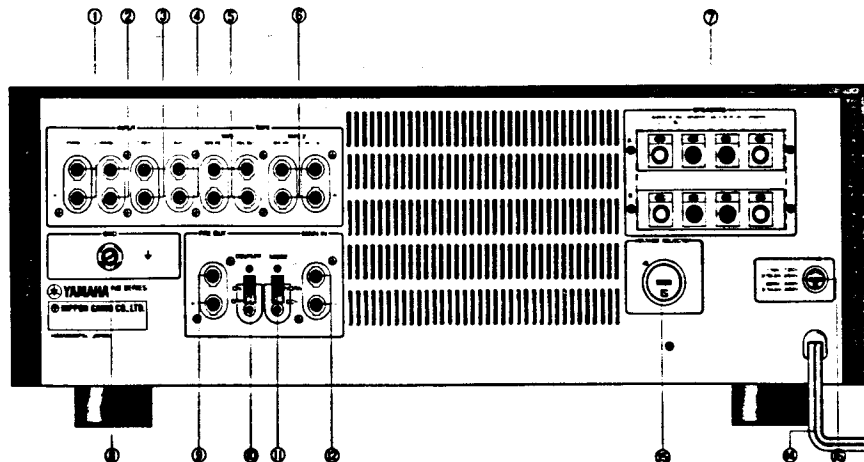

For Service Manuals Contact
MAURITRON TECHNICAL SERVICES
 8 Cherry Tree Rd, Chinnor
 Oxon OX9 4QY
 Tel:- 01844-351694 Fax:- 01844-352554
 Email:- enquiries@mauritron.co.uk

FRONT PANEL

- ① PEAK level meters
- ② METER switch
- ③ MODE selector
- ④ PHONE selector
- ⑤ REC OUT selector
- ⑥ INPUT selector
- ⑦ VOLUME control
- ⑧ BALANCE control
- ⑨ POWER indicator
- ⑩ POWER switch
- ⑪ HEADPHONE jack
- ⑫ SPEAKERS selector
- ⑬ a class/b class OPERATION switch
- ⑭ SUBSONIC FILTER switch
- ⑮ HIGH FILTER switch
- ⑯ BASS tone control & turnover switch
- ⑰ TREBLE tone control & turnover switch
- ⑱ AUDIO MUTING switch

REAR PANEL

- ① PHONE-1 input jacks
- ② PHONE-2 input jacks
- ③ TUNER input jacks
- ④ AUX input jacks
- ⑤ TAPE 1 PB/REC OUT jacks
- ⑥ TAPE 2 PB/REC OUT jacks
- ⑦ SPEAKER terminals
- ⑧ GROUND terminal
- ⑨ PRE OUT jacks
- ⑩ COUPLER switch
- ⑪ MODE (dc/normal) switch
- ⑫ MAIN IN jacks
- ⑬ AC OUTLETS
- ⑭ AC cord
- ⑮ VOLTAGE selector
- ⑯ primary fuse

INTERNAL VIEW

TOP VIEW

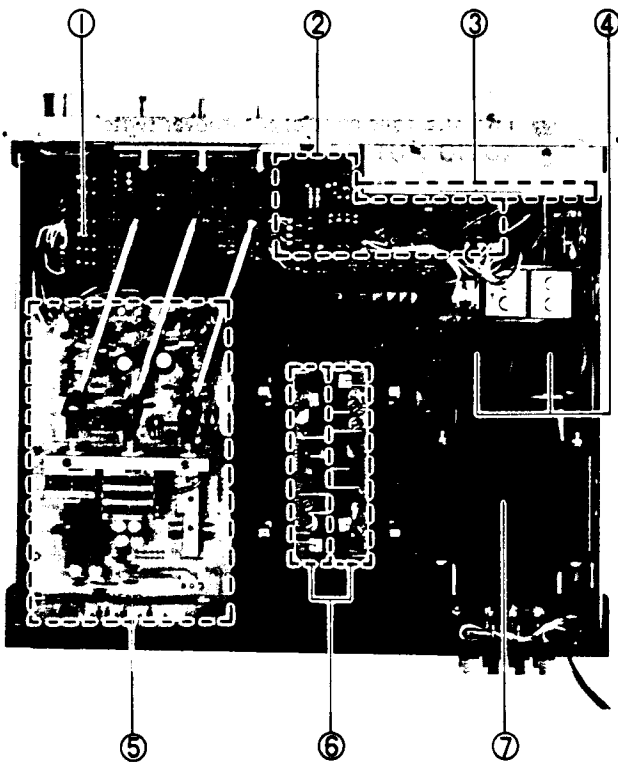

- ① TONE CONTROL CIRCUIT BOARD
NA06827
NA06826: U.S. & Canadian Models
- ② METER AMP CIRCUIT BOARD (NA06836)
- ③ LAMP CIRCUIT BOARD (NA 06838)
- ④ ELECTROLYTIC CAPACITOR CIRCUIT BOARD
(NA06837)
- ⑤ FUNCTION CIRCUIT BOARD
NA06833
NA06832: U.S. & Canadian Models
- ⑥ MAIN CIRCUIT BOARD
NA06844
NA06843: U.S. & Canadian Models
- ⑦ POWER TRANSFORMAR

For Service Manuals Contact
MAURITRON TECHNICAL SERVICES
 8 Cherry Tree Rd, Chinnor
 Oxon OX9 4QY
 Tel: 01844-351694 Fax: 01844-352554
 Email: enquiries@mauritron.co.uk

BOTTOM VIEW

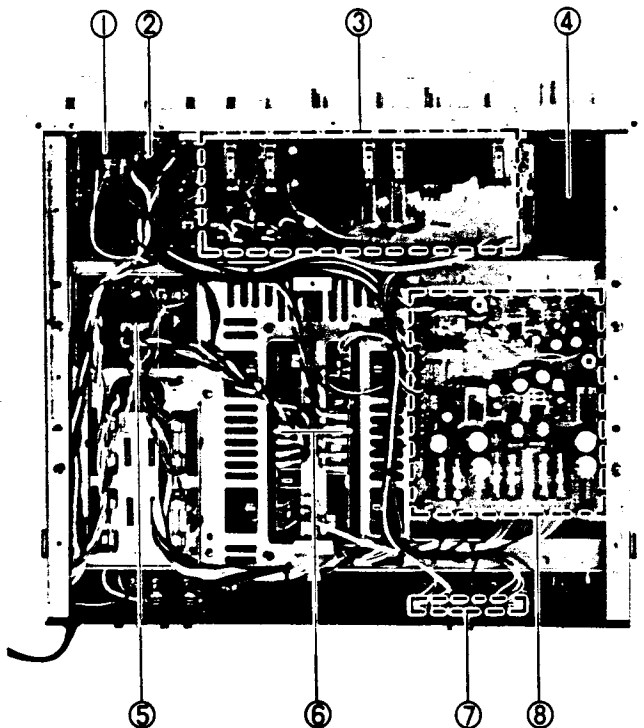

- ① HEADPHONE JACK
- ② SPEAKER SELECTOR SWITCH
- ③ TONE CONTROL CIRCUIT BOARD
- ④ VOLUME CONTROL
- ⑤ ELECTROLYTIC CAPACITOR CIRCUIT BOARD
- ⑥ MAIN CIRCUIT BOARD
- ⑦ COUPLER CIRCUIT BOARD
- ⑧ POWER CIRCUIT BOARD
NA06878: General & Australian Models
NA06789: U.S. & Canadian Models
NA06880: European & British Models

PARTIAL DISASSEMBLY

1. CABINET REMOVAL

- Remove screws 1 and 2 on both sides as shown in Photo 1.
- Lift cabinet upward and remove.

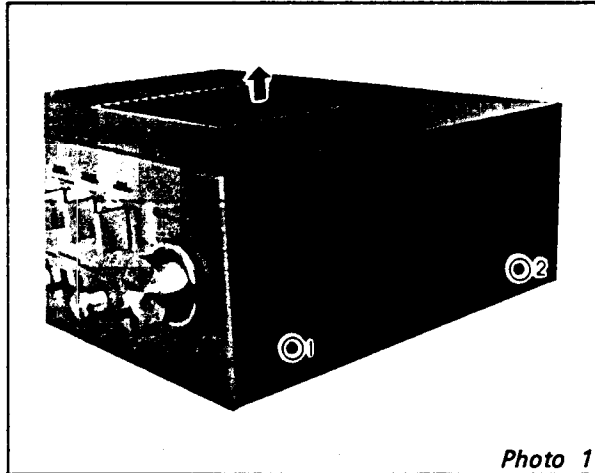

Photo 1

2. REAR PANEL REMOVAL

- Stand unit on side and remove screws 1 ~ 11 shown in Photo 2 and remove rear panel.

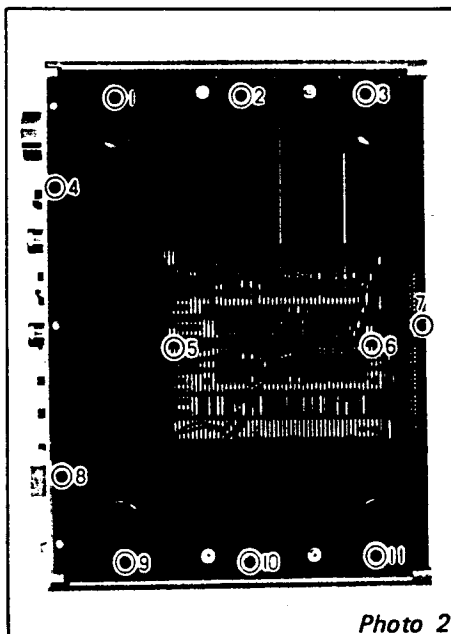

Photo 2

3. FUNCTION CIRCUIT BOARD REMOVAL

- Remove cabinet (refer to step 1)
- Remove screws 1 and 2 shown in Photo 3 and loosen screws 3 ~ 6.
- Slide the shield case toward the front-panel and remove.

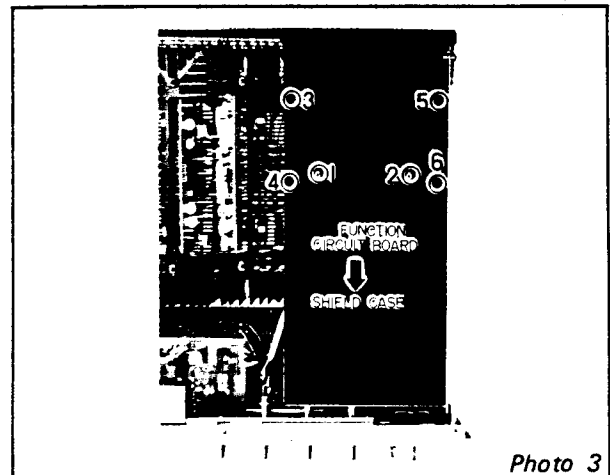

Photo 3

- Slide couplers 1 ~ 3 of the extension shaft in Photo 4 in the direction of the arrow and remove.
- Remove connected leads, then remove screws 4 ~ 9 shown in Photo 4.
- Remove rear panel screws 1 ~ 8 shown in Photo 5, then remove the function circuit board together with the pin jacks.

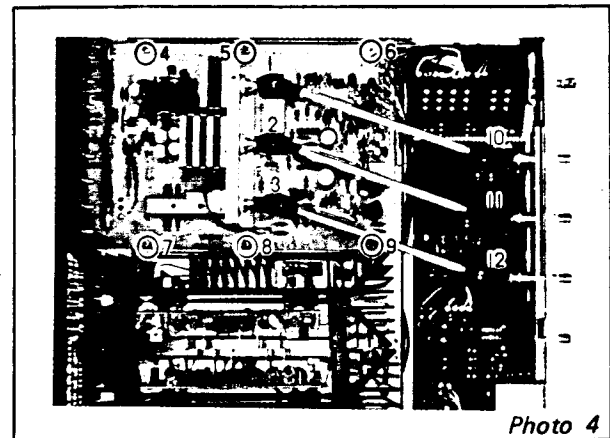

Photo 4

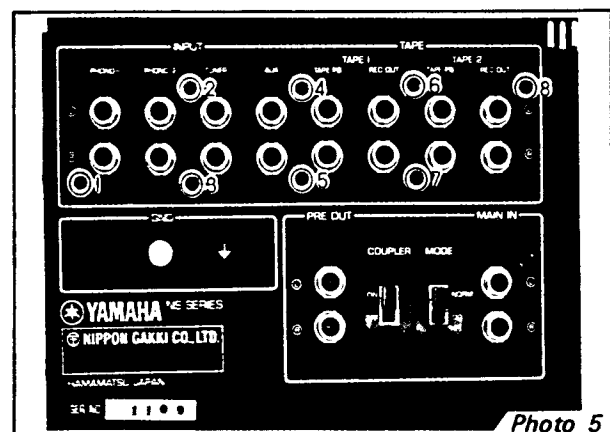
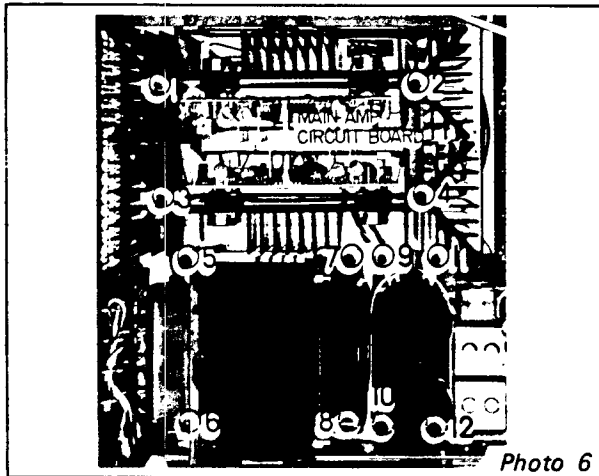

Photo 5

4. MAIN AMP CIRCUIT BOARD REMOVAL

- a. Remove cabinet (refer to step 1).
- b. Remove rear panel (refer to step 2).
- c. Remove screws 1, 2 (for RCH), 3 and 4 (for LCH), then remove lead wires connected from the bottom portion of the chassis to the main Amp circuit board.



5. POWER TRANSFORMER REMOVAL

- a. Remove cabinet (refer to step 1).
- b. Remove the rear panel (refer to step 2).
- c. Remove lead wire from the bottom of the chassis to the transformer.
- d. Remove screws 5 ~ 8 and remove power transformer.

6. CHEMICAL CONDENSER CIRCUIT BOARD REMOVAL

- a. Remove cabinet (refer to step 1).
- b. Remove the rear panel (refer to step 2)
- c. Remove the wires leading from the bottom of the chassis to the chemical condenser circuit board.
- d. Then remove the chemical condenser circuit board by removing screws 9 ~ 12.

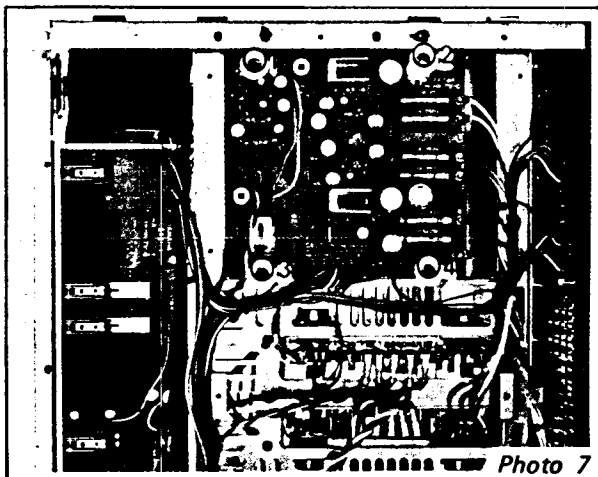

7. POWER CIRCUIT BOARD REMOVAL

- a. Remove the rear panel (refer to step 1).
- b. Remove screws 1-4 and the lead wire, then remove the power circuit board.

8. COUPLER CIRCUIT BOARD REMOVAL

- a. Remove the rear panel (refer to step 2).
- b. Remove rear panel screws 1 ~ 5, then remove coupler circuit board.

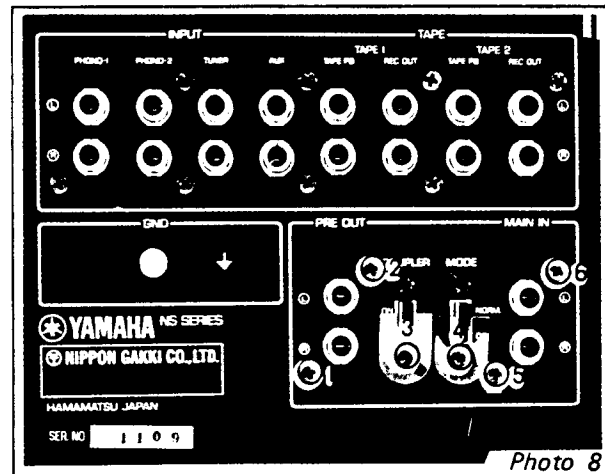

9. FRONT PANEL REMOVAL

- a. Remove cabinet (refer to step 1).
- b. Remove rear panel (refer to step 2).
- c. Remove all knobs on the front panel. Use hexagonal wrench to loosen the nuts on the SPEAKERS, MODE, PHONO SELECTOR, REC OUT SELECTOR, INPUT SELECTOR.
Pull and remove TONE CONTROL and VOLUME knobs.
- d. Remove BALANCE knob from side of chassis after loosening screws 1 ~ 2 shown in Photo 9.

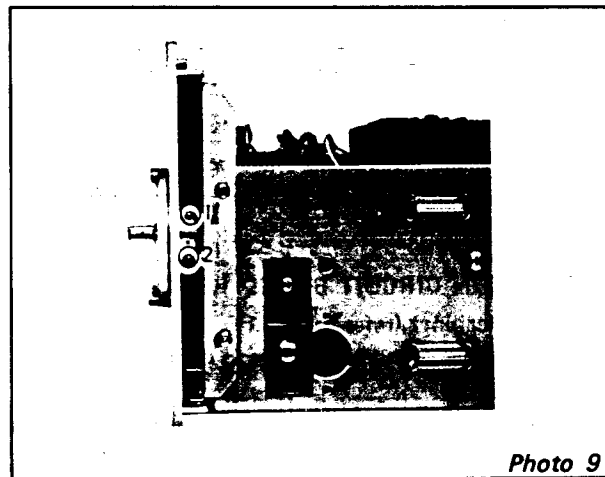

- e. Remove lead wires of the level meter and the power source indicating lamp.

LEADS ARE CONNECTED AS SHOWN IN FIGURE 1.

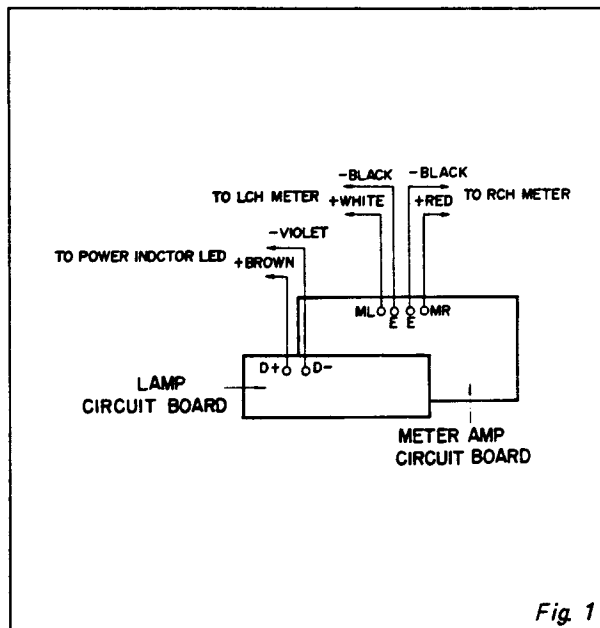

Fig. 1

- f. Remove screws 1-3 in Photo 10 and screws 1-3 in Photo 11 and remove the front panel.

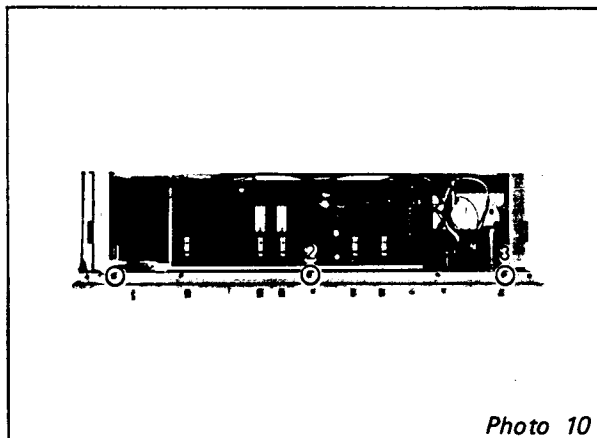

Photo 10

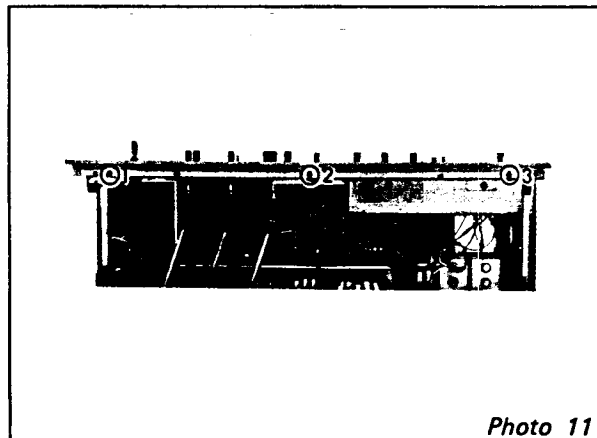

Photo 11

10. LAMP CIRCUIT BOARD

- Remove cabinet (refer to step 1).
- Remove screws 1 and 2 shown in Photo 12 and remove the lamp circuit board with brackets and acrylic illumination plate attached.

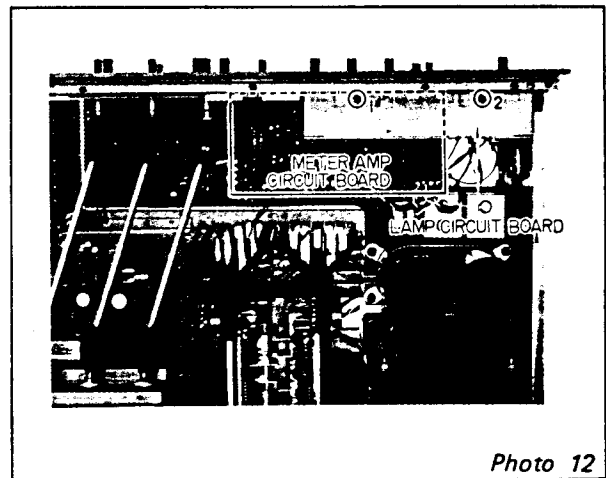

Photo 12

11. METER CIRCUIT BOARD

- Remove the front panel (refer to step 9)
 - Slide extension shaft joints 10 ~ 12 toward the function circuit board.
 - Remove screws 1 ~ 6 shown in Photo 13 and remove the meter circuit board together with brackets.
- * In this case, screws 7 ~ 9 for the stopper are removed in advance.

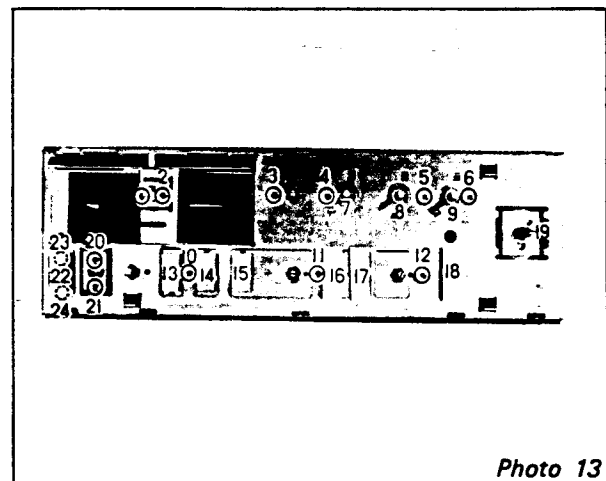

Photo 13

12. TONE CONTROL CIRCUIT BOARD REMOVAL

- Remove the front panel (refer to step 1).
- Remove lead wire connected to the circuit board in advance.

- c. Pull and remove knobs 14 ~ 19 of the lever switch shown in Photo 13.
- d. Remove screws 10 ~ 13 and remove the tone control circuit board.

13. VOLUME CIRCUIT BOARD REMOVAL

- a. Remove the front panel (refer step 9).
- b. Remove the jumper wire of the tone control circuit board.
- c. Remove nut 20 shown in Photo 13 and remove the volume circuit board.

14. HEAD PHONE JACK

- a. Remove the front panel (refer step 9).
- b. Remove screws 20 and 21 and remove the jack.

15. POWER SWITCH REMOVAL

- a. Remove the front panel (refer step 9).
- b. Pull and remove lever knob 23. Then remove screws 24, 25 and remove the power switch.

16. DROPPING THE REAR PANEL

- a. Remove cabinet (refer step 1).
- b. Remove the power source (refer to step 2).
- c. Remove screws 1 ~ 8 shown in Photo 5.
- d. Remove screw 1 and remove screw 2 on both sides. Then rear panel can be dropped to the rear.

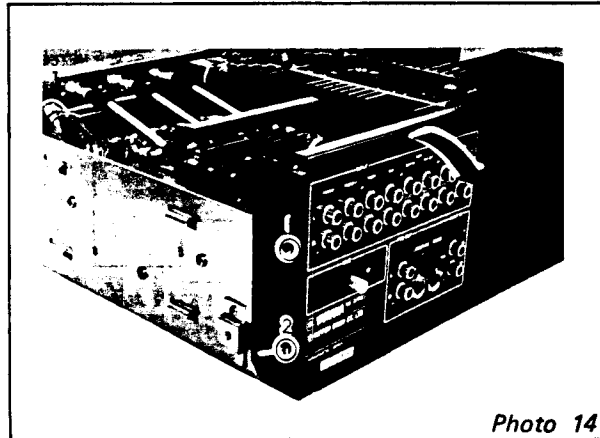

Photo 14

For Service Manuals Contact
MAURITRON TECHNICAL SERVICES
8 Cherry Tree Rd, Chinnor
Oxon OX9 4QY
Tel:- 01844-351694 Fax:- 01844-352554
Email:- enquiries@mauritron.co.uk

ADJUSTMENT

Carry out adjustments on both the "L" and "R" channels.

1. ADJUSTMENT OF THE IDLING CURRENT IN THE MAIN AMPLIFIER

1.1 With Class B operation (OPERATION switch at TP1 and TP2 of the main circuit board and adjust VR-302 so the reading is 25mV.

302 so the reading is 25mV.

(Refer Fig. 1)

1.2 With Class A operation (OPERATION switch at

CLASS A), connect tester between terminals TP1 and TP2 of the main circuit board and adjust VR-303 so the reading is 300mV.

(Refer Fig. 1)

2. ADJUSTMENT OF THE MID-POINT POTENTIAL OF THE MAIN AMPLIFIER

Connect tester between terminals TP1 and TP3 of the main circuit board and adjust VR-301 so the reading is 0V. (Refer Fig. 1)

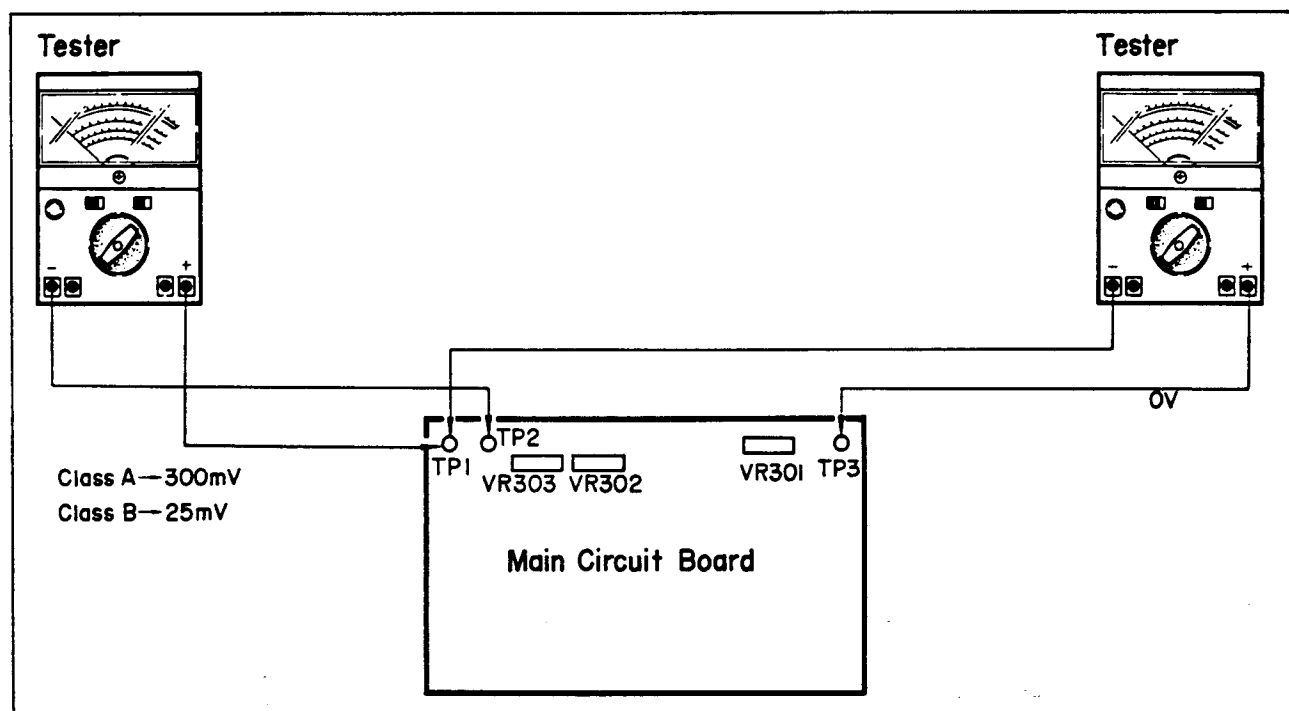

3. ADJUSTMENT OF DISTORTION IN THE MC AMPLIFIER

Connect a low frequency oscillator to PHONO-1 terminal and apply a 20KHz 30V output signal (signal source impedance 22 ohms).

Adjust VR-101 ("L" ch.) and VR-102 ("R" ch.) on the function circuit board for minimum distortion at the REC OUT terminals of TAPE 1 or TAPE 2. (Refer Fig. 2)

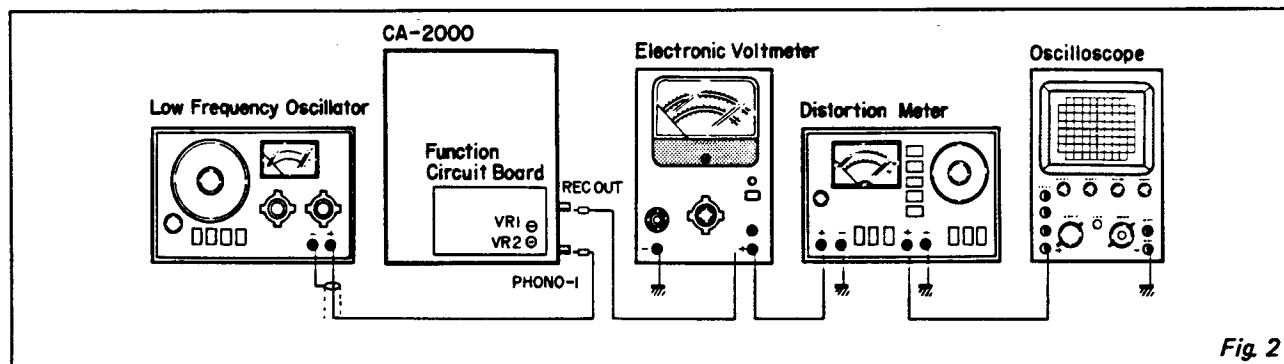

Fig. 2

4. ADJUSTMENT OF THE METERS

4.1 Adjust the "Zero Adjustment" screw at the lower part of the meter so the meter indicates "0" under no-signal conditions.

4.2 Connect an 8 ohm (over 150W) dummy resistor

to the speaker output terminal and adjust VR-501 ("L" ch) and VR-502 ("R" ch) of the meter amplifier circuit board until the meter indicates 0dB at an output of 100W (28.28V, 1KHz). (Refer Fig. 3).

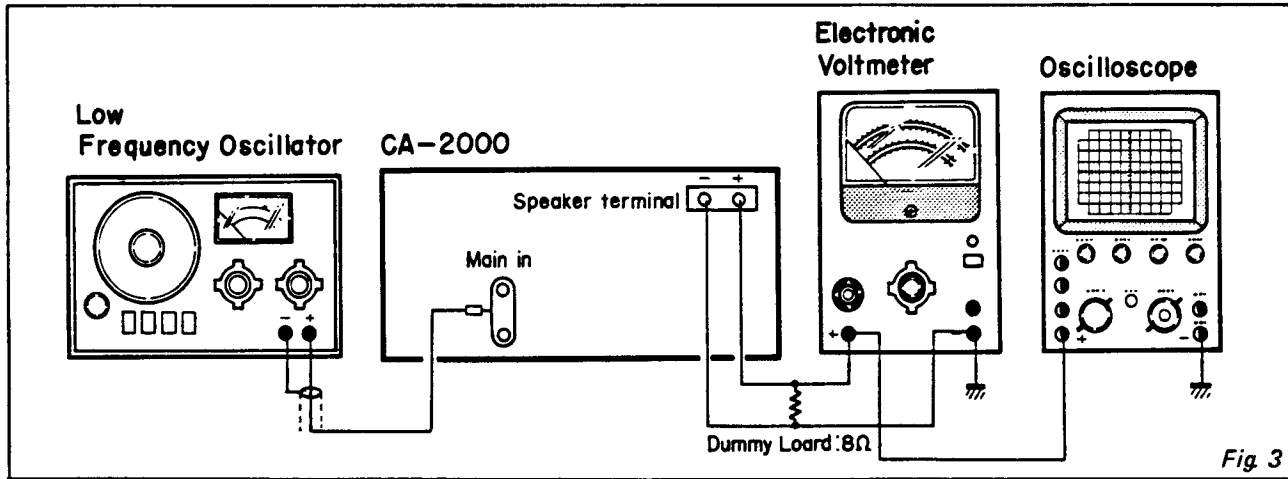

Fig. 3

For Service Manuals Contact
MAURITRON TECHNICAL SERVICES
8 Cherry Tree Rd, Chinnor
Oxon OX9 4QY
Tel:- 01844-351694 Fax:- 01844-352554
Email:- enquiries@mauritron.co.uk

FUNCTION CIRCUIT BOARD

For Service Manuals Contact
 MAURITRON TECHNICAL SERVICES
 8 Cherry Tree Rd, Chinnor
 Oxon OX9 4QY
 Tel: 01844-351694 Fax: 01844-352554
 Email: enquiries@mauritron.co.uk

PHONO 1

PHONO 2

TUNER

AUX

TAPE PB

TAPE 1

REC OUT

TAPE PB

TAPE 2

REC OUT

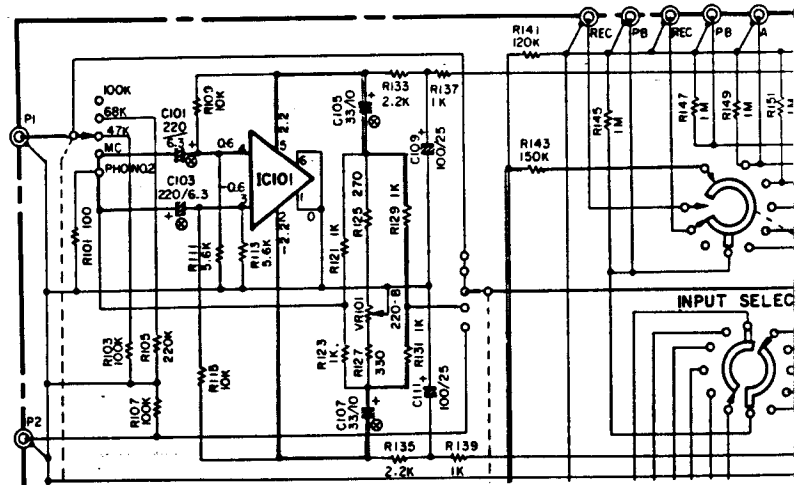
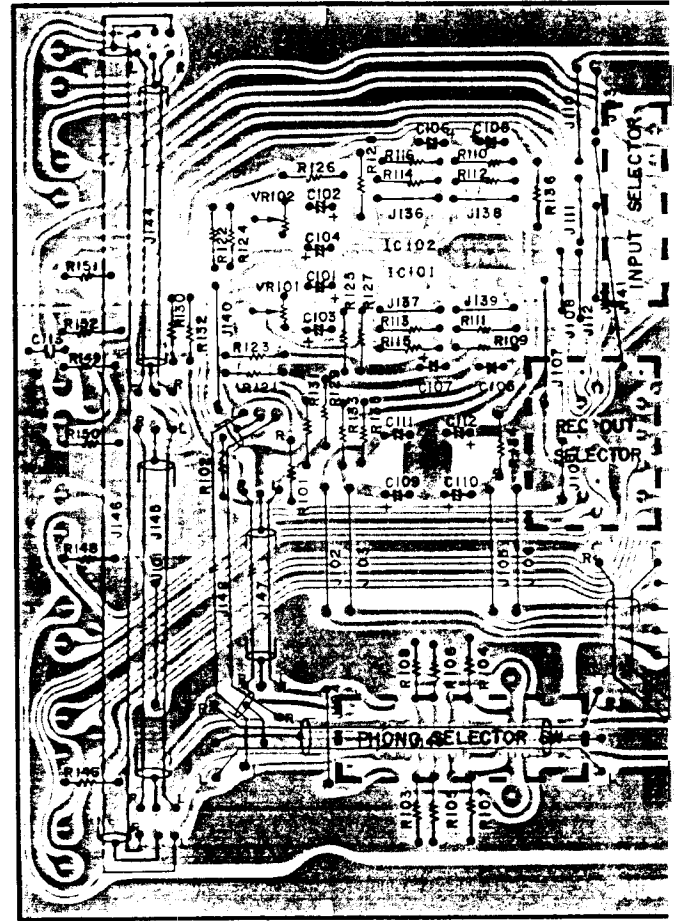

CUI BOARD

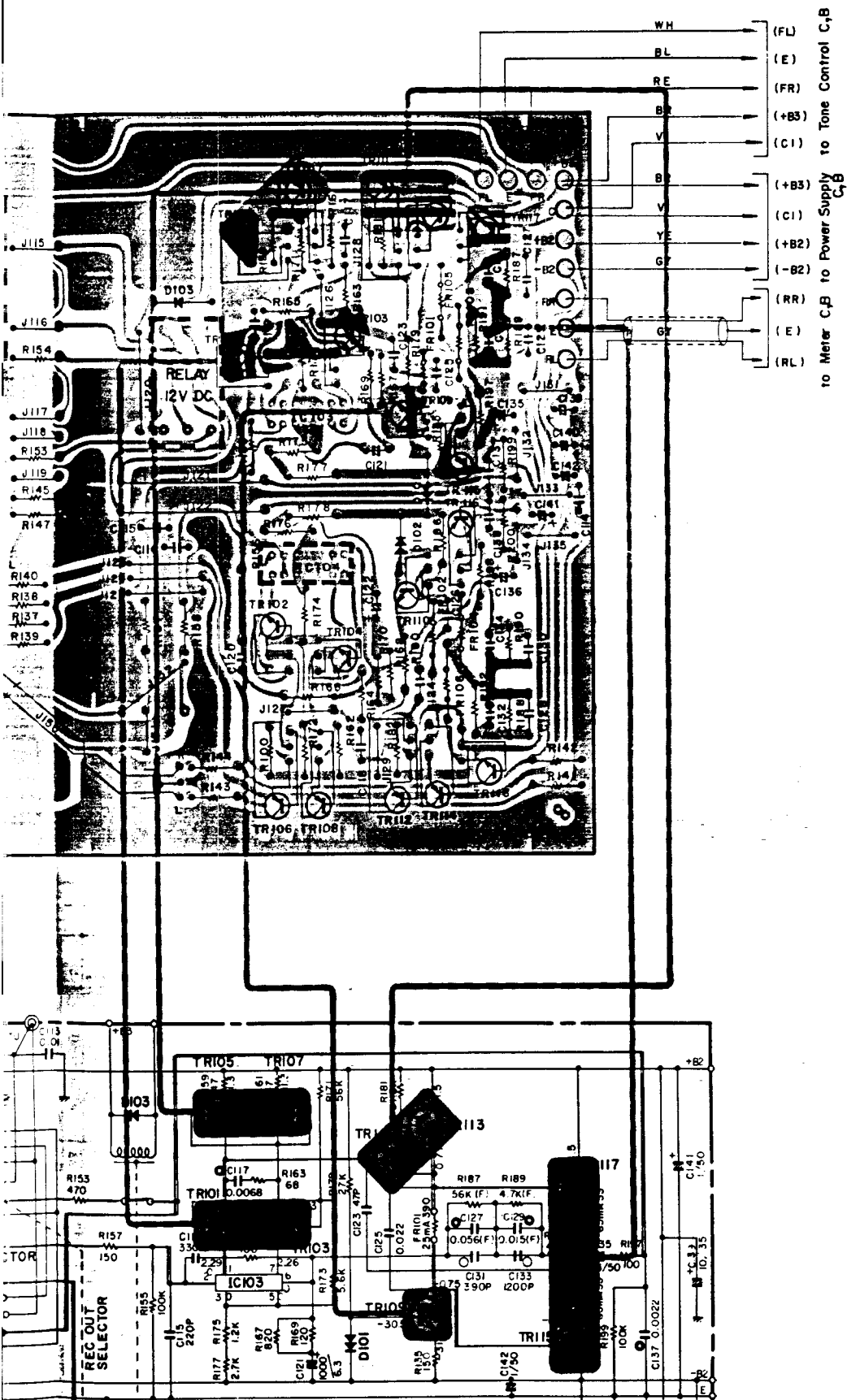

TONE CONTROL CIRCUIT BOARD

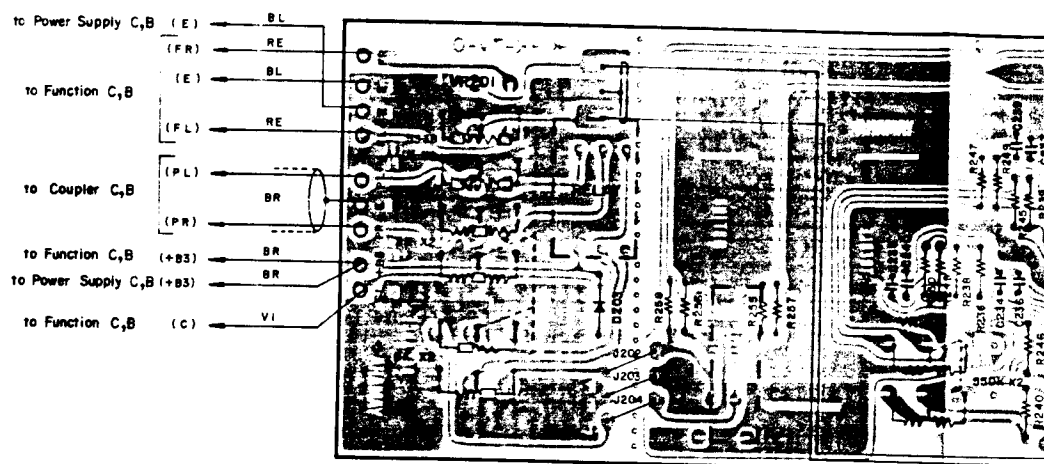

For Service Manuals Contact
MAURITRON TECHNICAL SERVICES
 8 Cherry Tree Rd, Chinnor
 Oxon OX9 4QY
 Tel:- 01844-351694 Fax:- 01844-352554
 Email:- enquiries@mauritron.co.uk

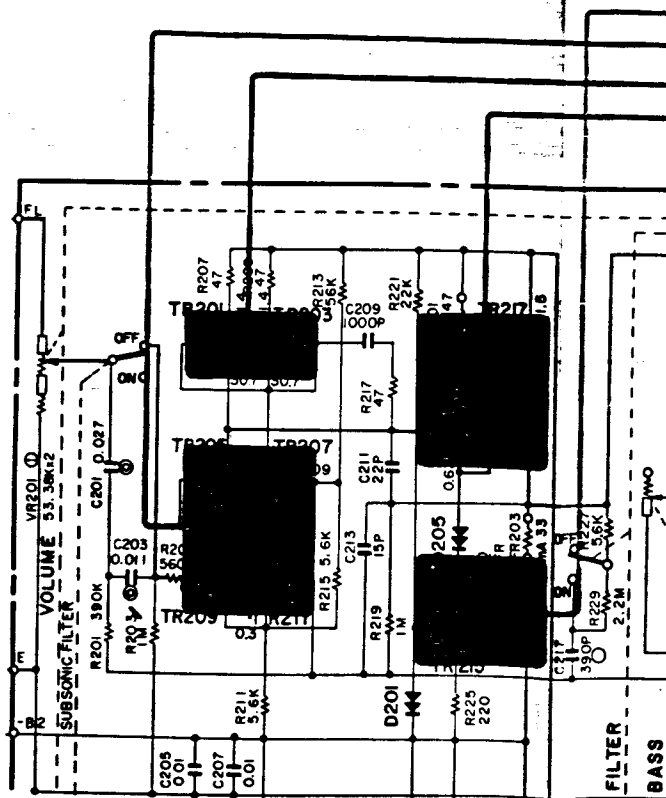

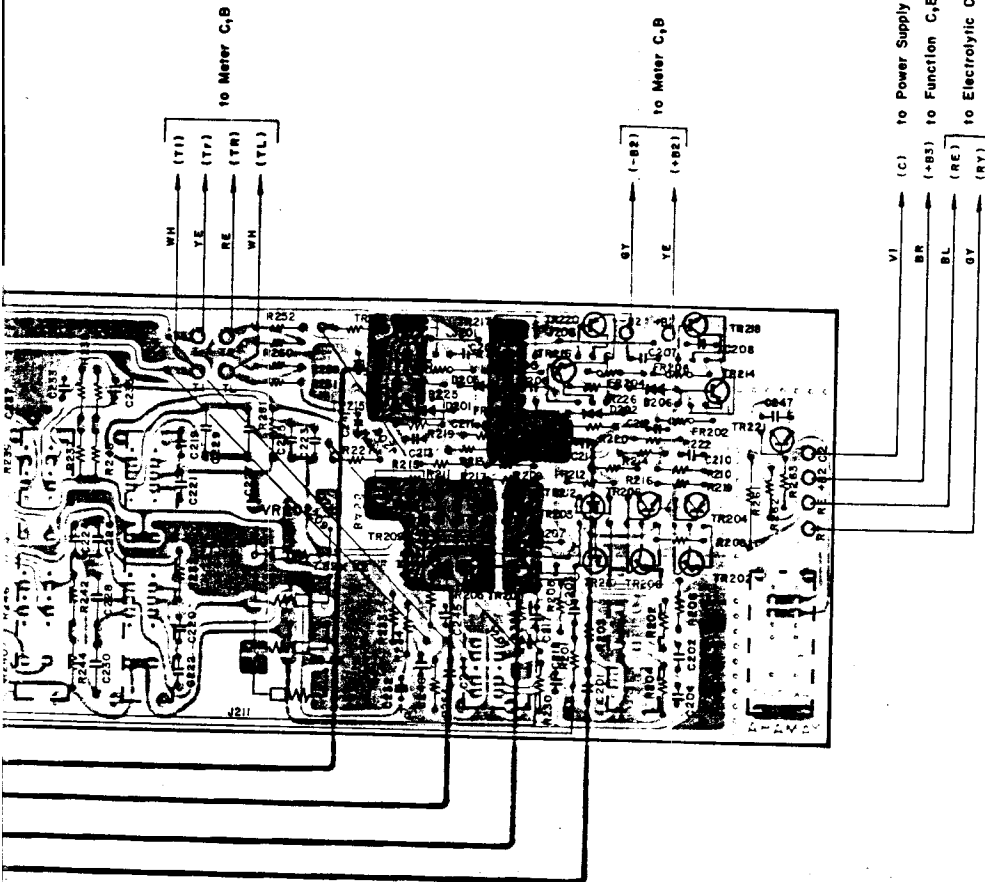
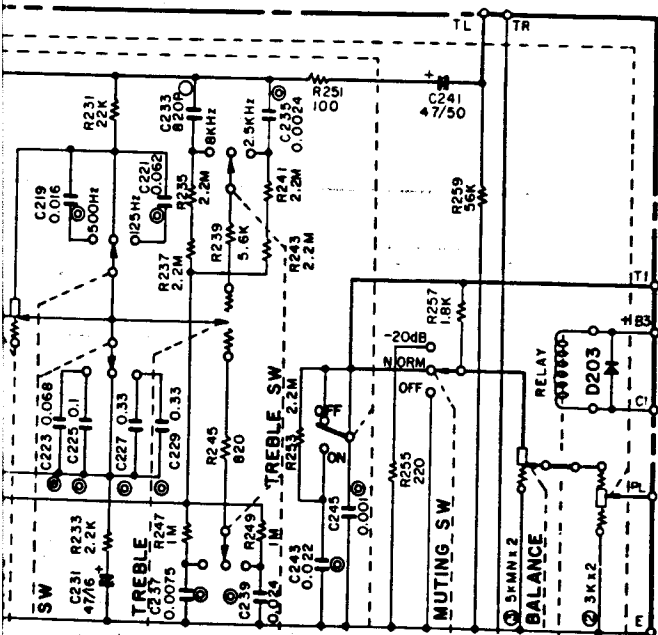

VI → to Power Supply C₁B
 BR → to Function C₁B
 BL → to Electrolytic Cap, C₁B
 GY → to Electrolytic Cap, C₁B
 (-BS) →
 (+BS) →
 (RE) →
 (RY) →

For Service Manuals Contact
MAURITRON TECHNICAL SERVICES
 8 Cherry Tree Rd, Chinnor
 Oxon OX9 4QY
 Tel: 01844-351694 Fax: 01844-352554
 Email: enquiries@mauritron.co.uk

METER CIRCUIT BOARD

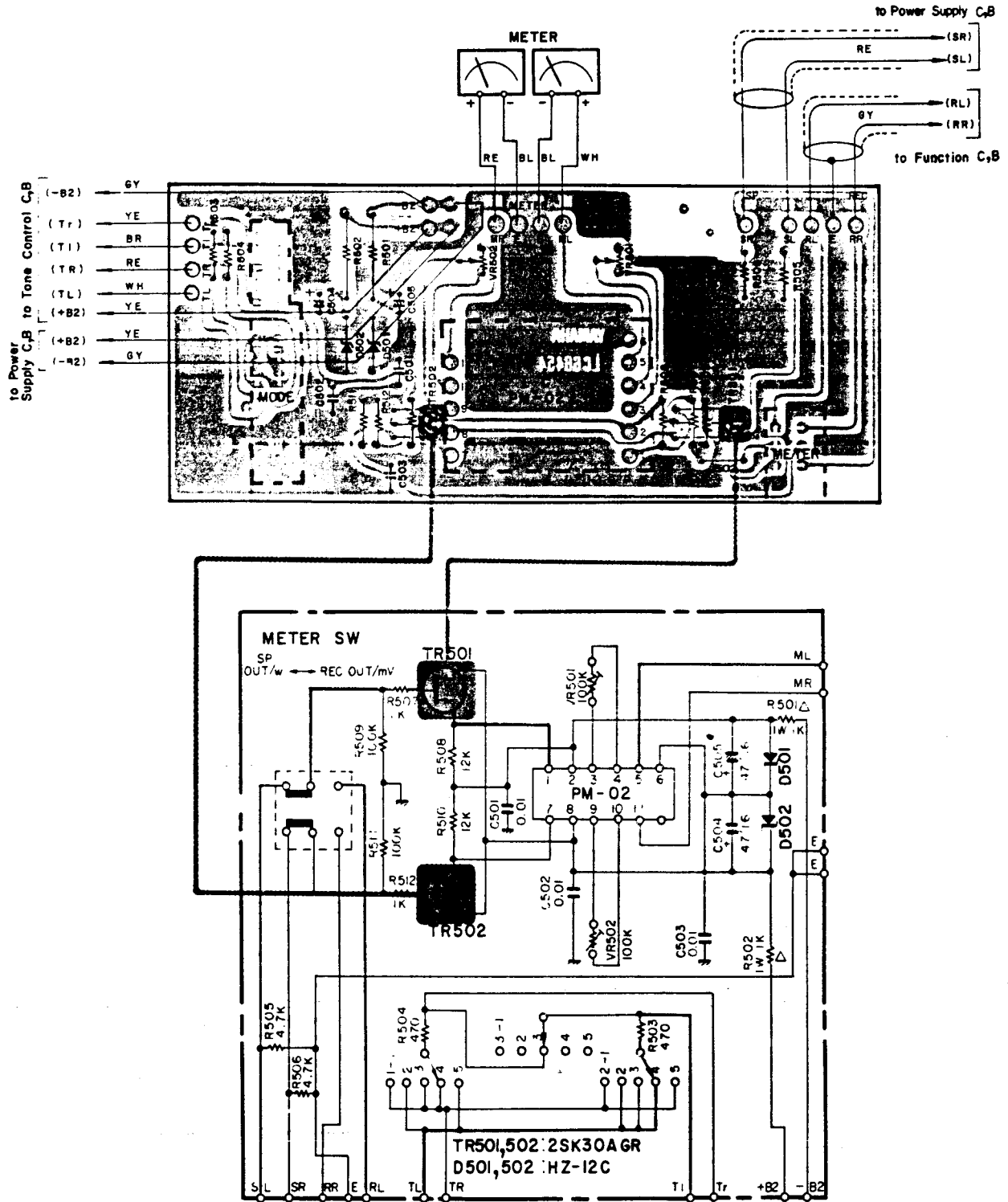

COUPLER CIRCUIT BOARD

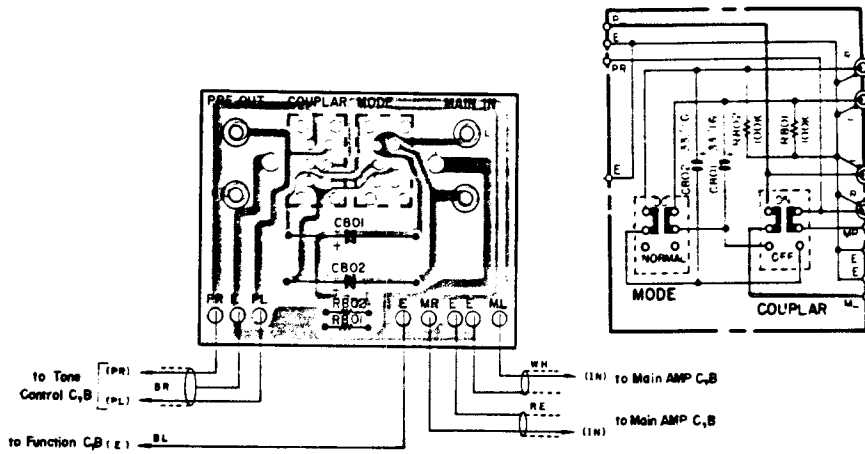

LAMP CIRCUIT BOARD

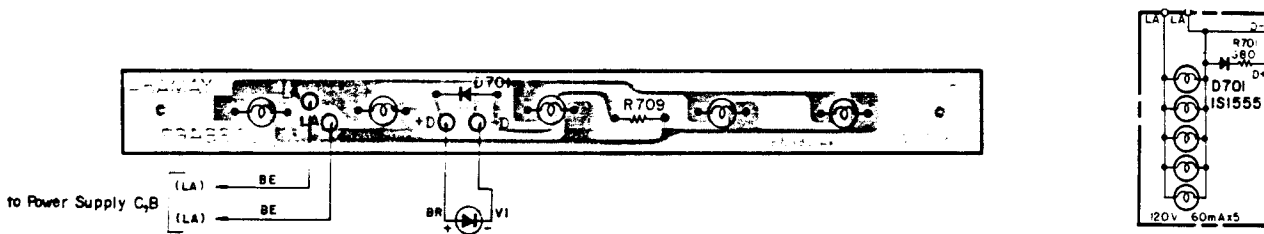

ELECTROLYTIC CAPACITOR CIRCUIT BOARD

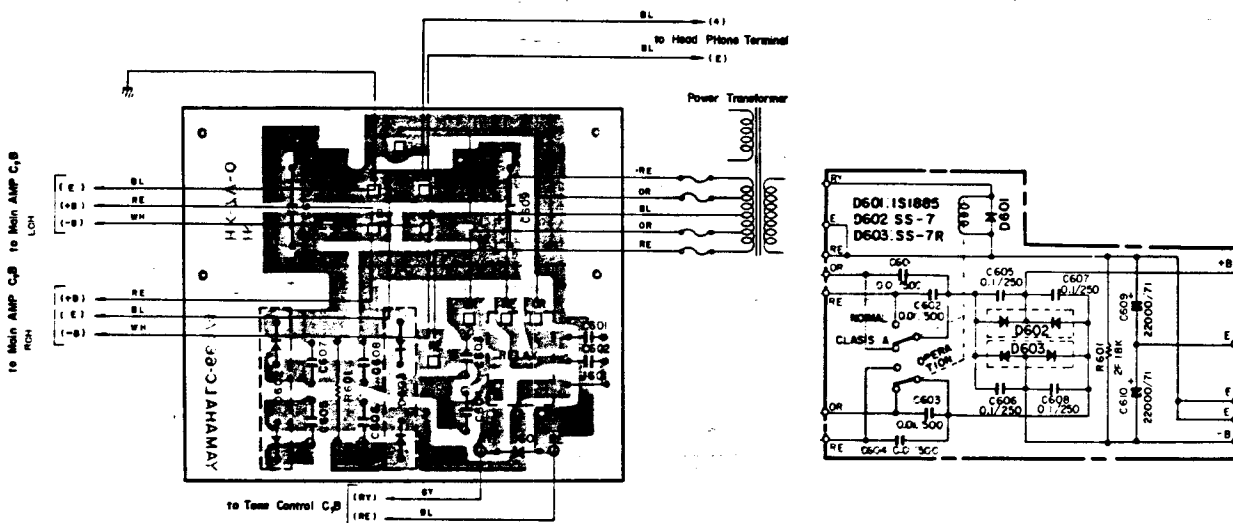

MAIN CIRCUIT BOARD

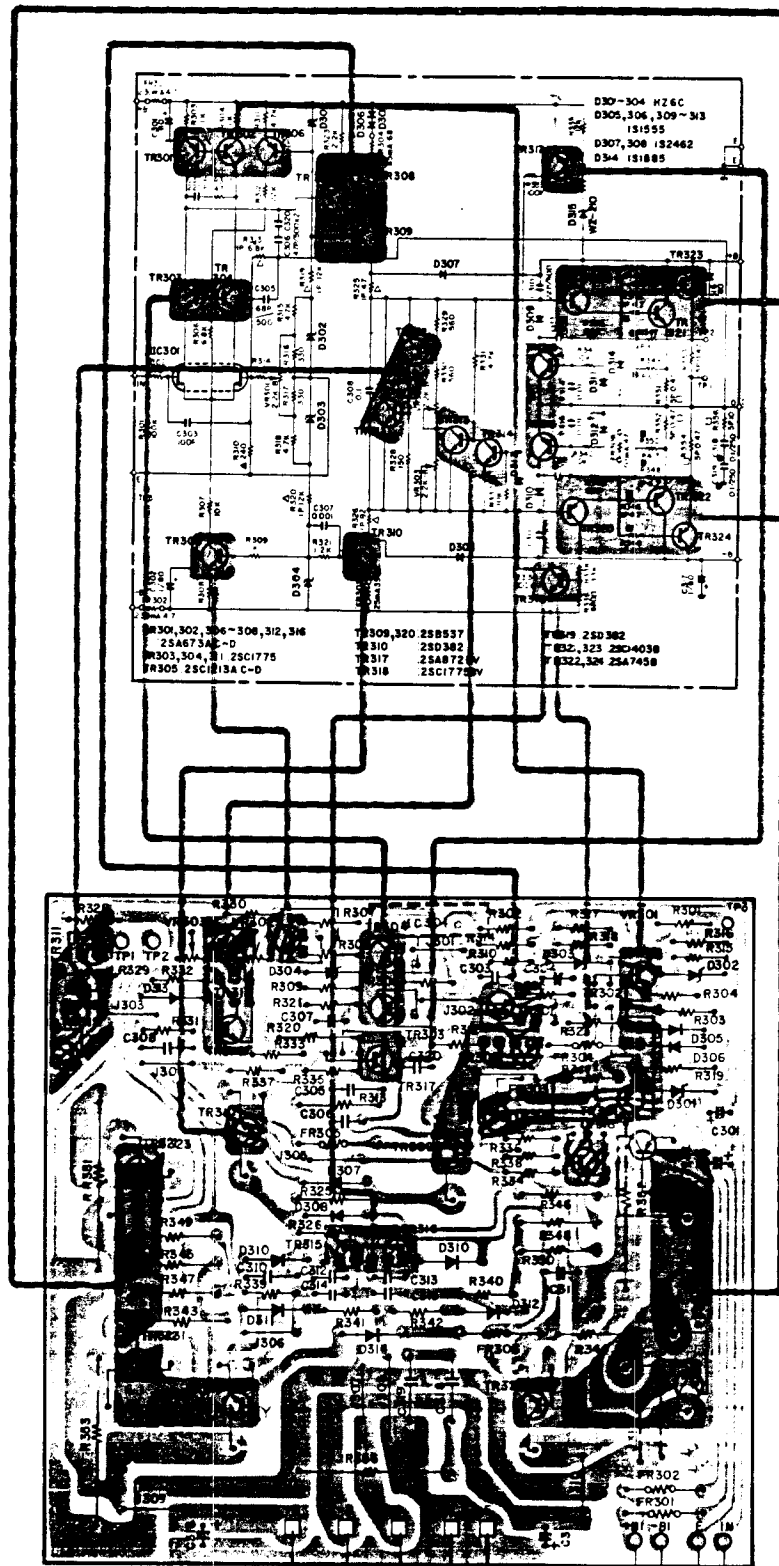

D301-304 H26C
 D305,306,309-313
 1S1555
 D307,308 1S2462
 D314 1S1885

R301,302,306-308,312,316
 25A67345-0
 R303,304,31 25C1775
 R305 25C1813A C-D

TR309,320 25B537
 TR310 25D382
 TR317 25A8726
 TR318 25C1775B

TR319 25D382
 TR321,323 25D4038
 TR322,324 25A7458

For Service Manuals Contact
MAURITRON TECHNICAL SERVICES
 8 Cherry Tree Rd, Chinnor
 Oxon OX9 4QY
 Tel: 01844-351694 Fax: 01844-352554
 Email: enquiries@mauritron.co.uk

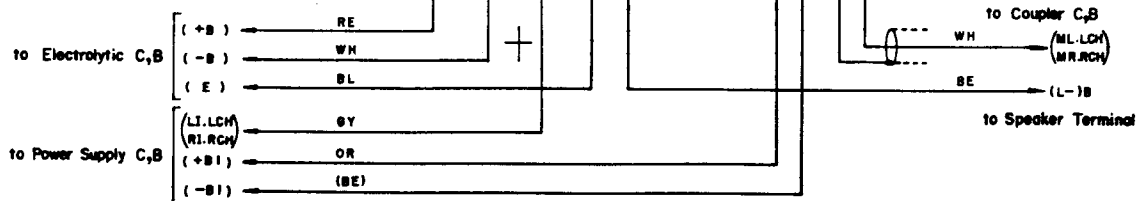

POWER SUPPLY CIRCUIT BOARD

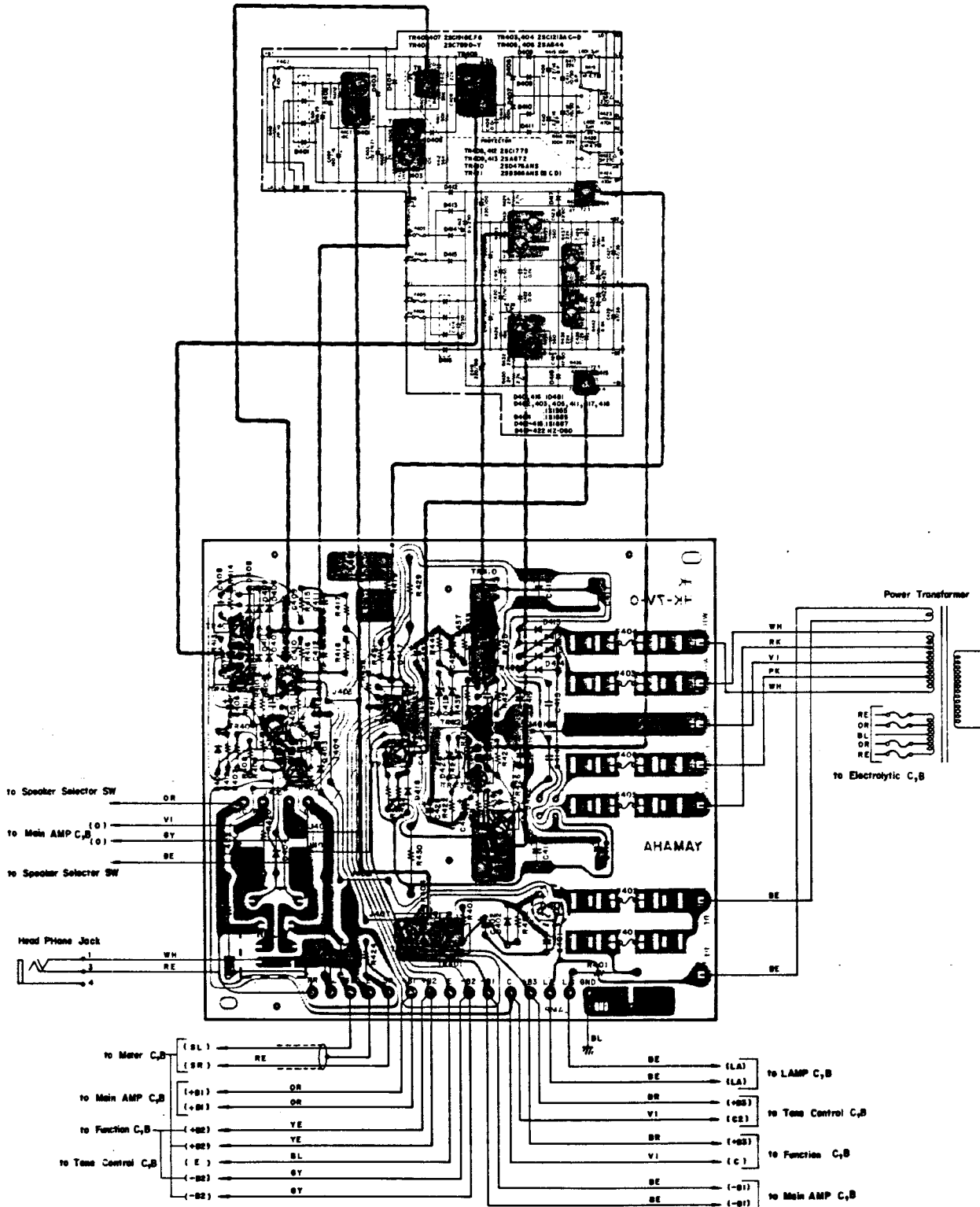

BLOCK DIAGRAM

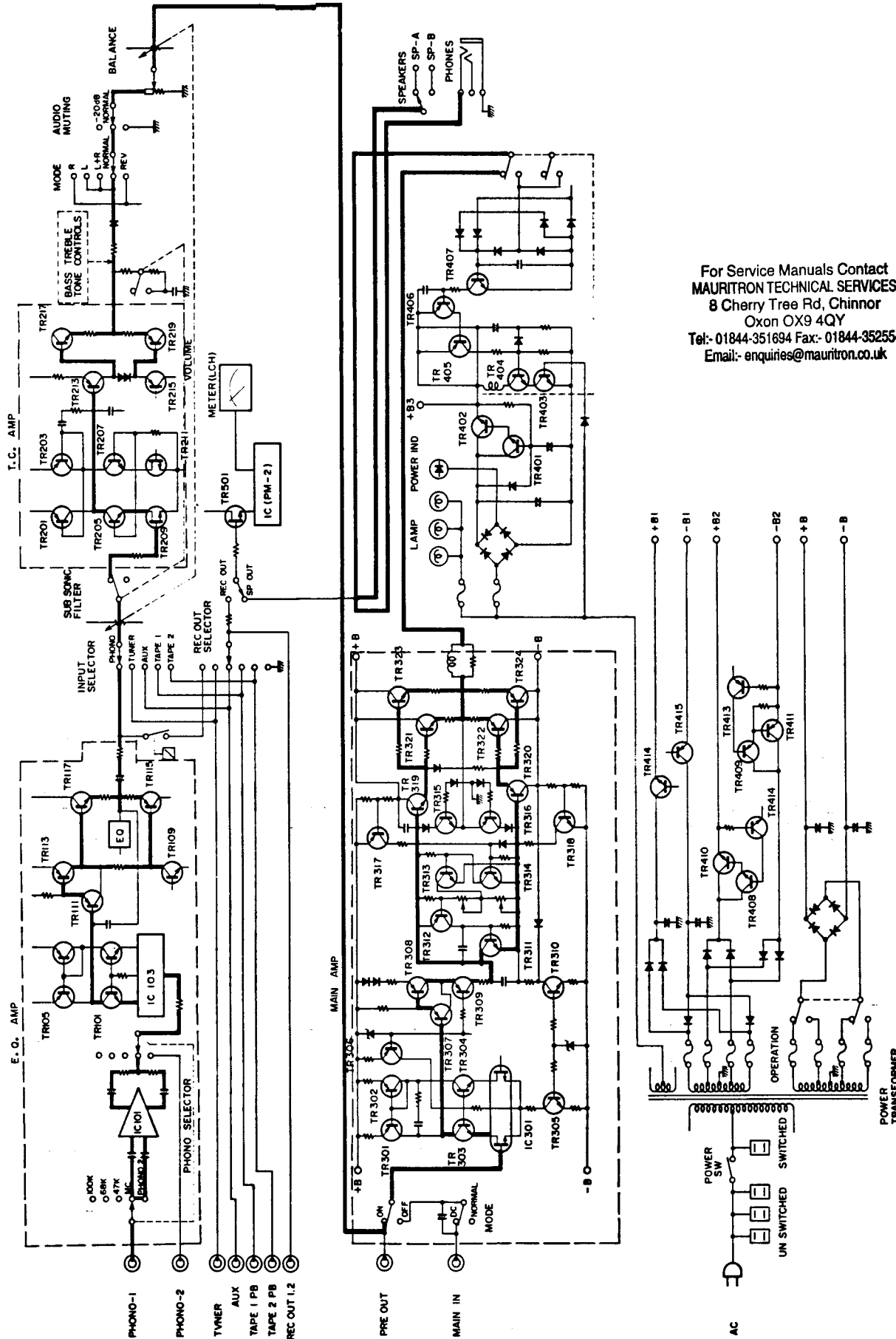

For Service Manuals Contact
MAURITRON TECHNICAL SERVICES
 8 Cherry Tree Rd, Chinnor
 Oxon OX9 4QY
 Tel:- 01844-351694 Fax:- 01844-352554
 Email:- enquiries@mauritron.co.uk

PARTIAL CHANGES MADE ACCORDING TO DESTINATION

▼ U.S. & CANADIAN MODELS

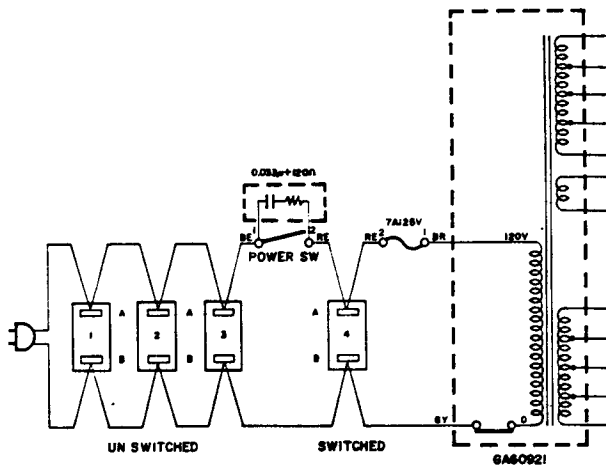

▼ AUSTRALIAN MODEL

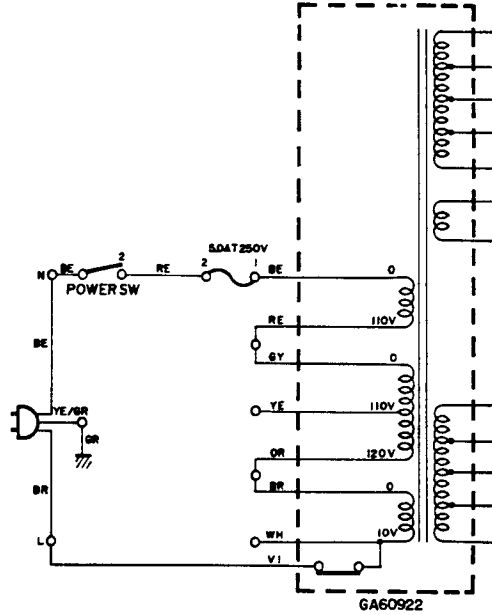

▼ GENERAL MODEL

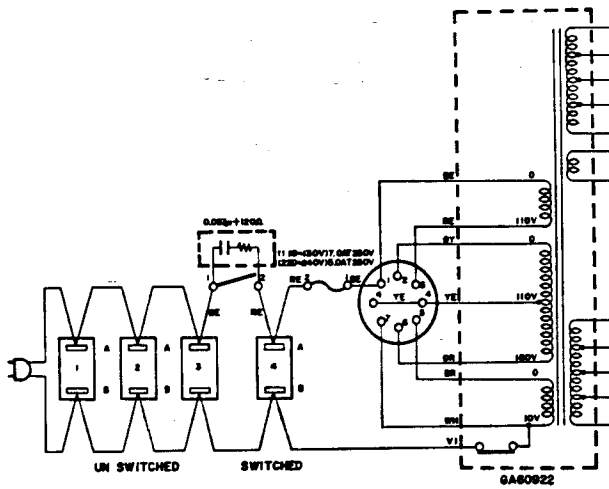

▼ EUROPEAN MODEL

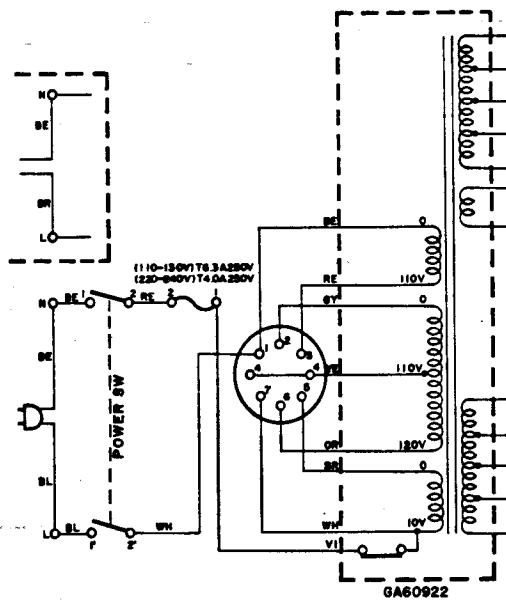

For Service Manuals Contact
MAURITRON TECHNICAL SERVICES
 8 Cherry Tree Rd, Chinnor
 Oxon OX9 4QY
 Tel: 01844-351694 Fax: 01844-352554
 Email: enquiries@mauritron.co.uk

OVERALL SCHE

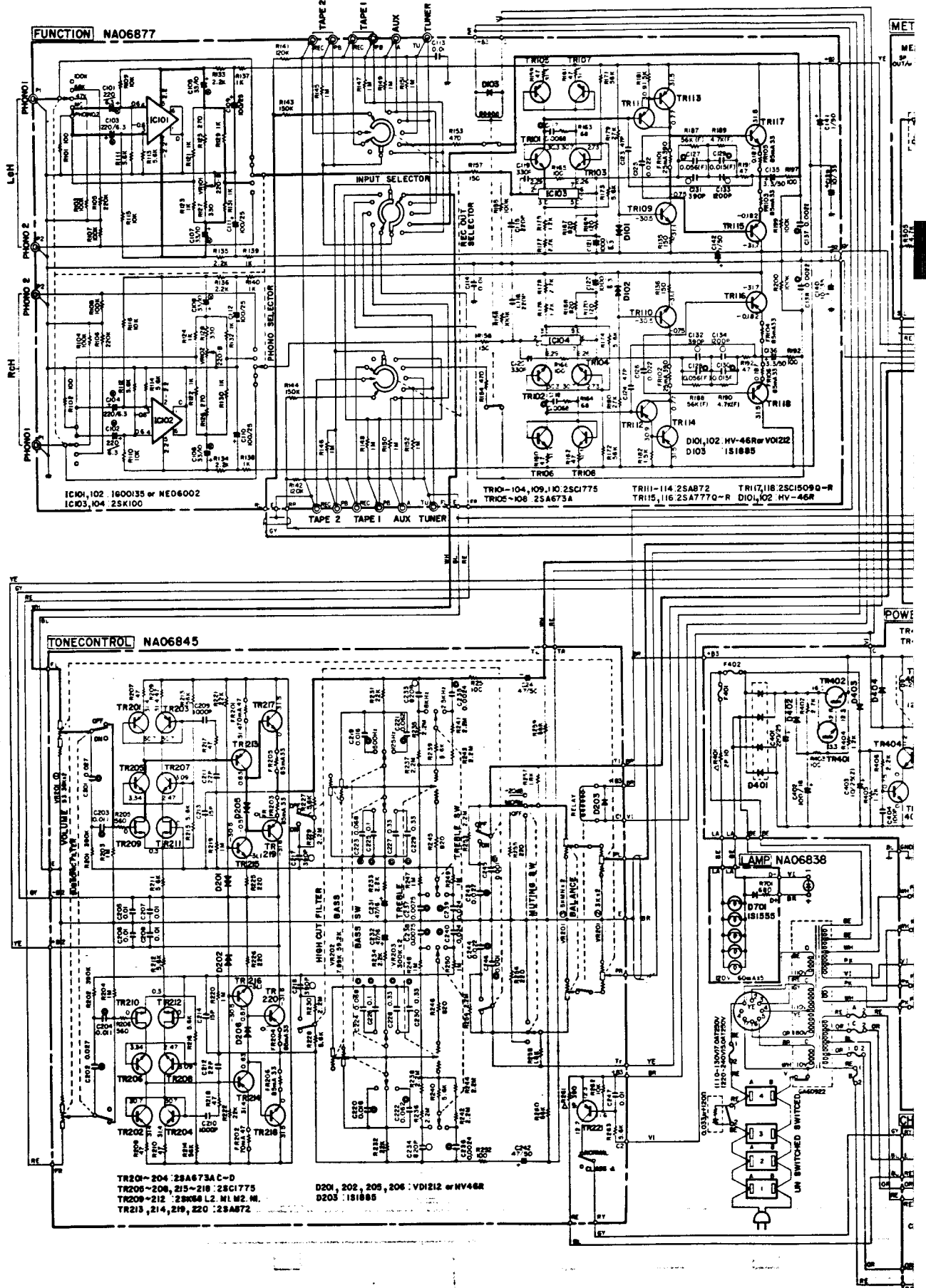

SCHEMATIC DIAGRAM

For Service Manuals Contact
MAURITRON TECHNICAL SERVICES
 8 Cherry Tree Rd, Chinnor
 Oxon OX9 4QY
 Tel: 01844-351694 Fax: 01844-352554
 Email: enquiries@mauritron.co.uk

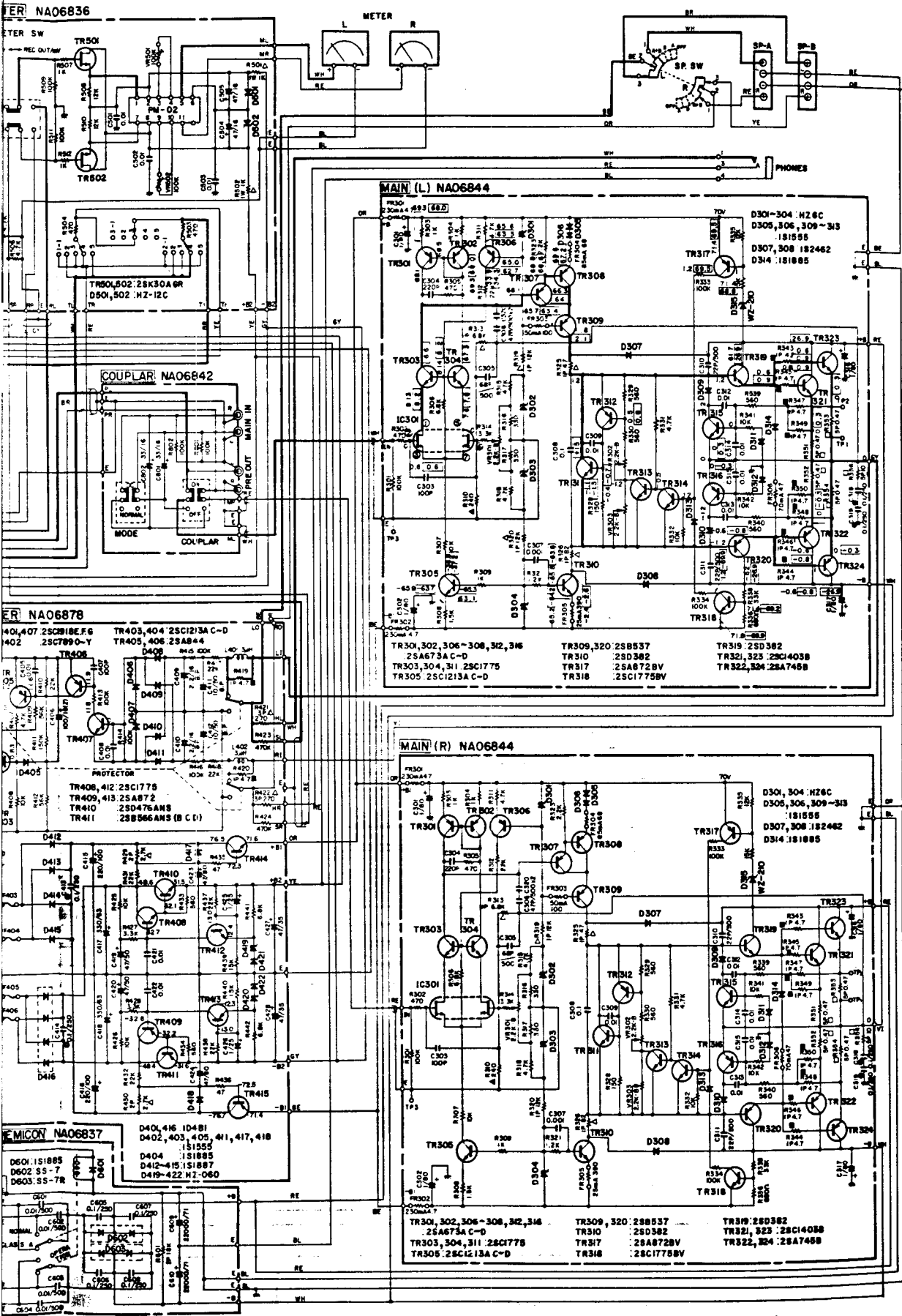

WIRING

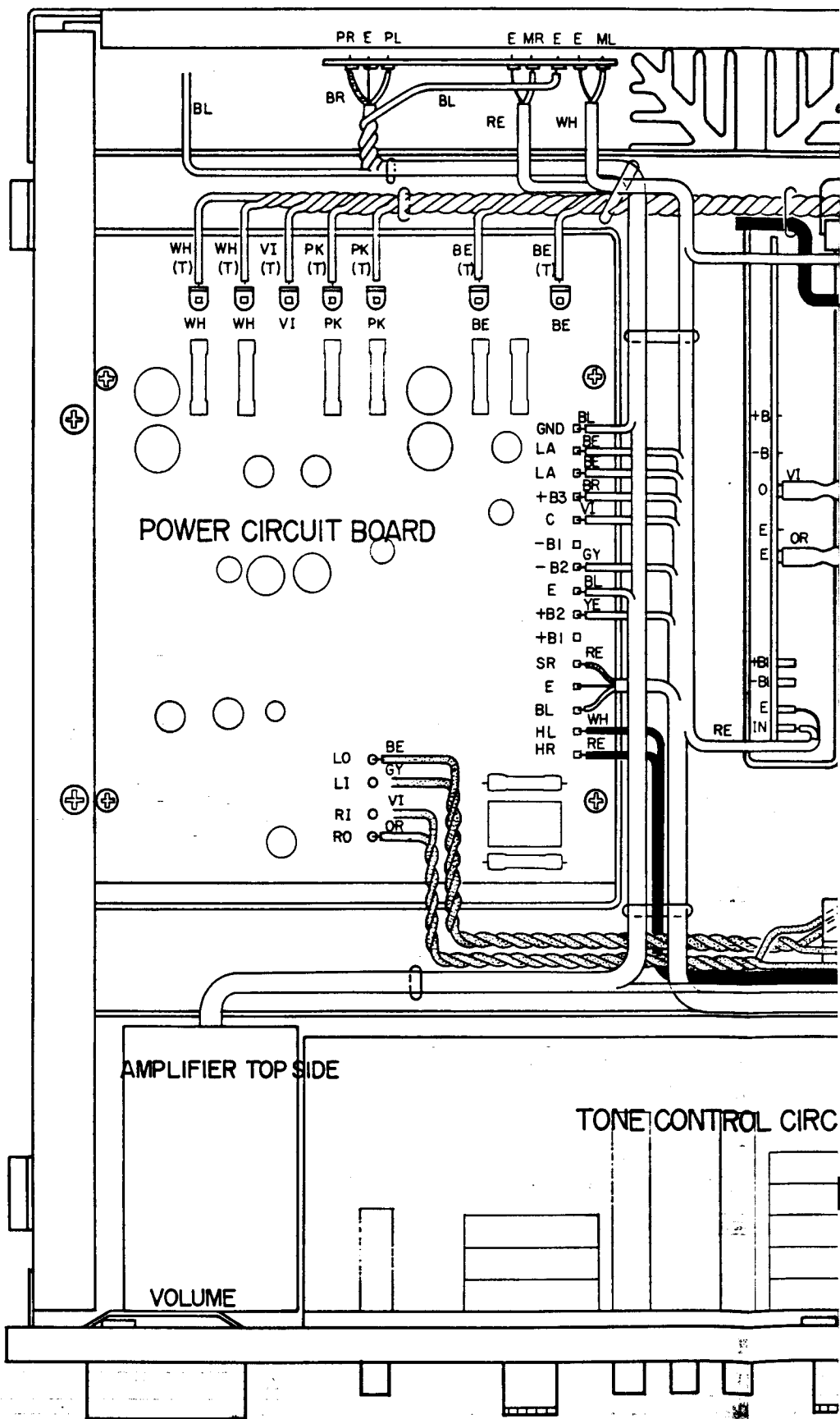

For Service Manuals Contact
MAURITRON TECHNICAL SERVICES
 8 Cherry Tree Rd, Chinnor
 Oxon OX9 4QY
 Tel:- 01844-351694 Fax:- 01844-352554
 Email:- enquiries@mauritron.co.uk

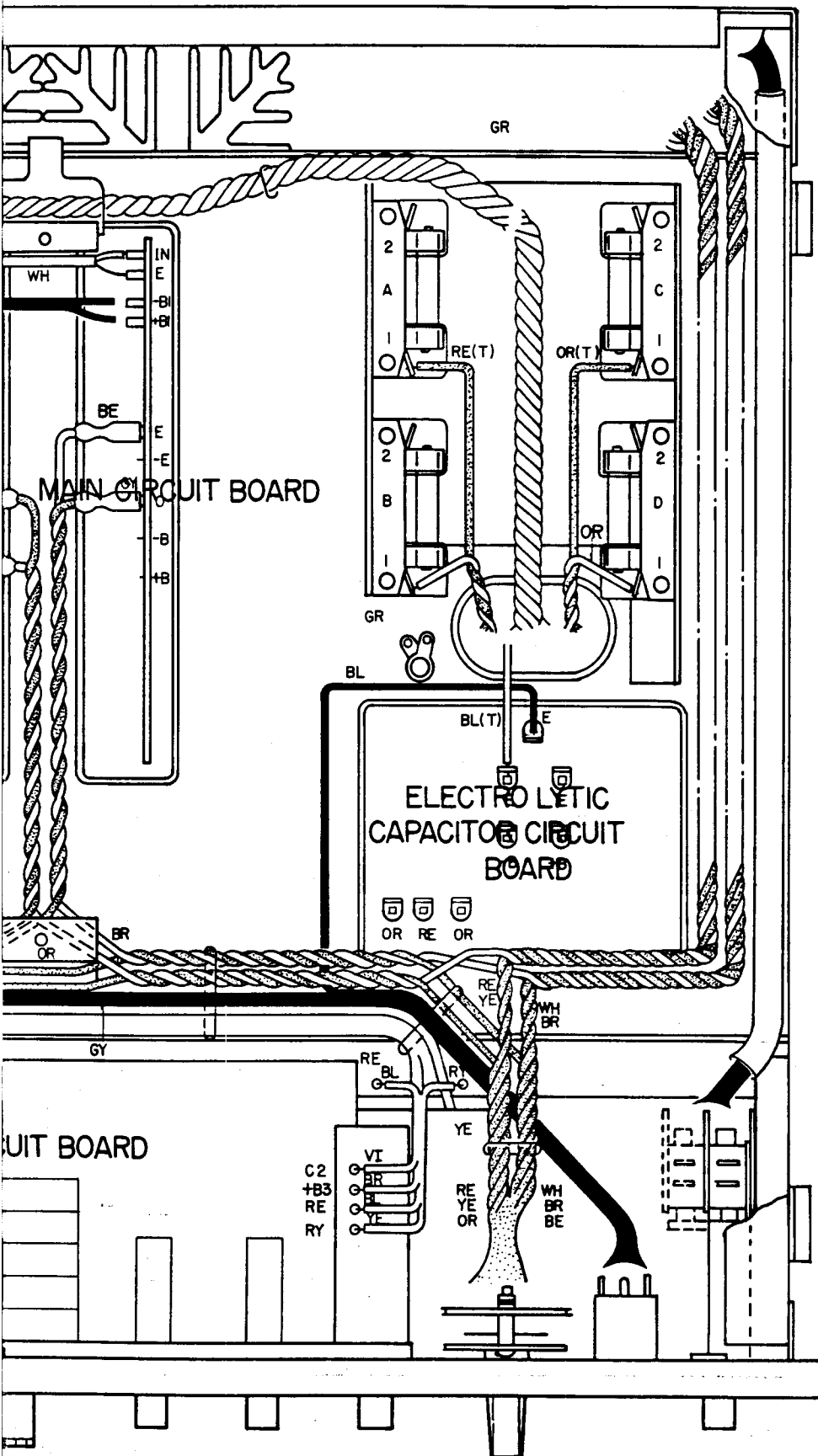

PACKAGE

For Service Manuals Contact
MAURITRON TECHNICAL SERVICES
8 Cherry Tree Rd, Chinnor
Oxon OX9 4QY
Tel:- 01844-351694 Fax:- 01844-352554
Email:- enquiries@mauritron.co.uk

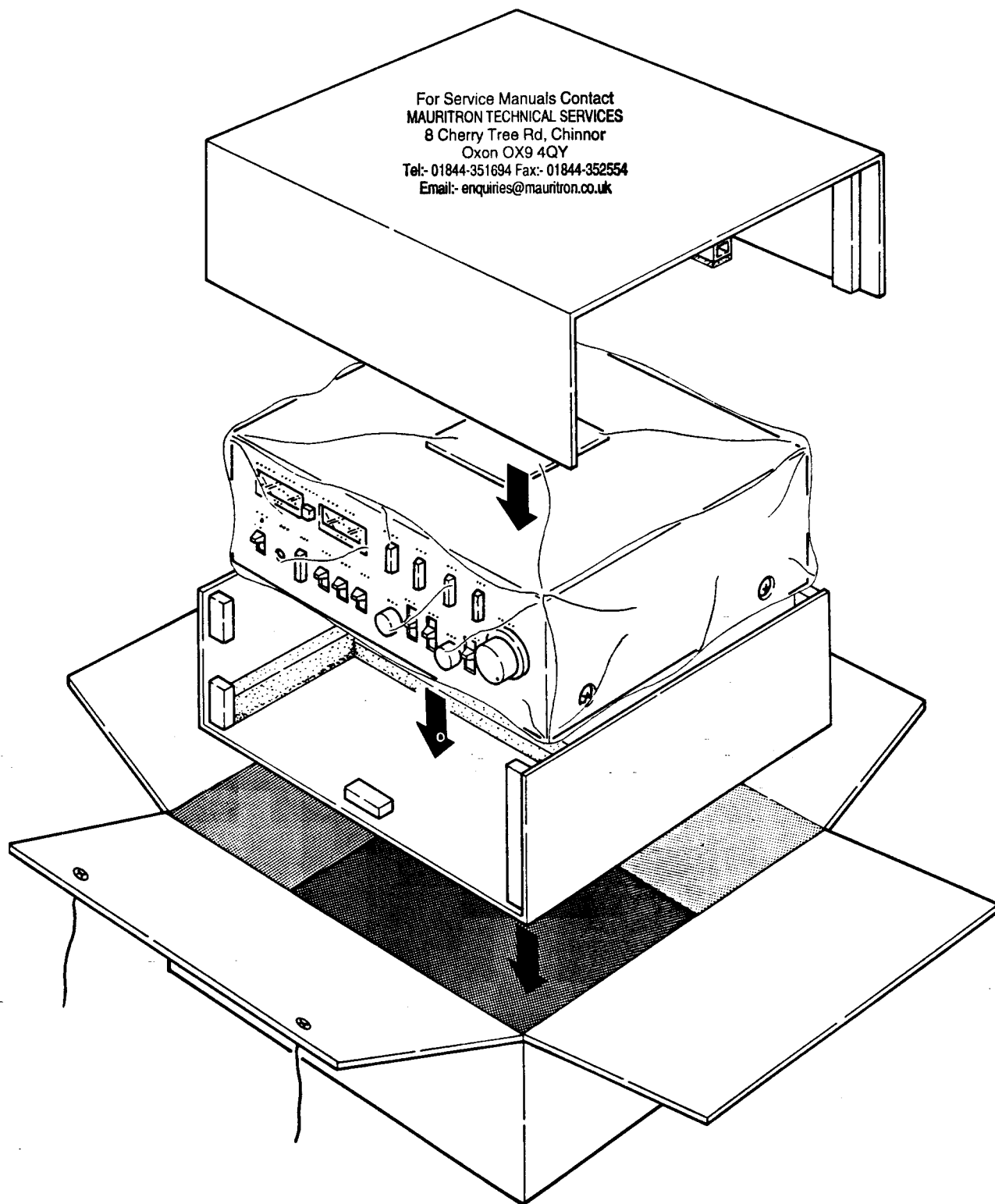

PARTS LIST

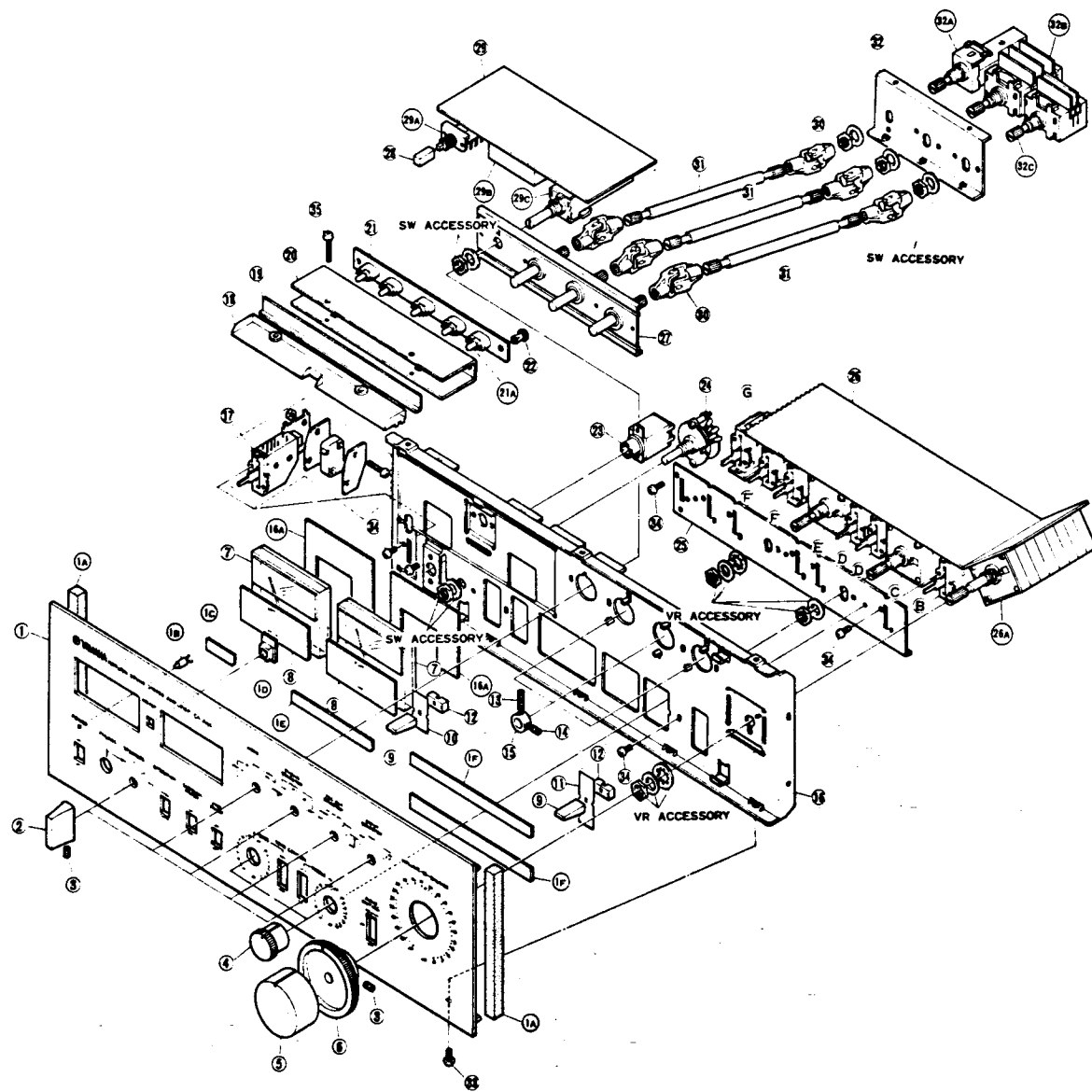

Ref. No.	Part No.	Description	Remarks	Common Models
1	32:00:00 NB:07:78:30	FRONT PANEL	フロントパネル R. U. C. A. E. B	
-A	42:00:00 CB:07:80:30	Shade Tape	遮光テープ	
-B	42:00:00 MZ:06:84:40	LED Ass'y	LED Ass'y	
-C	42:00:00 CB:07:90:20	Film for Apron	SWエプロン	
-D	32:00:00 CB:07:79:70	Push Button Frame	プッシュボタン枠	
-E	42:00:00 CB:07:90:00	Film for Apron	SWエプロン	
-F	42:00:00 CB:07:90:10	-do.-	"	
2	32:00:00 BA:06:44:20	Switch Knob	SWツマミ	
3	42:00:00 EZ:00:01:90	Hexagonal Set Screw	六角セットネジ	
4	32:00:00 BA:06:88:10	Knob	ツマミ	
5	32:00:00 BA:06:92:50	Double Knob	ダブルツマミ	
6	32:00:00 BA:06:91:20	-do.-	"	
7	42:00:00 JI:00:04:40	Peak Levek Meter	ピークレベルメーター	
8	32:00:00 BA:06:91:10	Meter Panel	メーターパネル	
9	32:00:00 CB:06:85:70	Lever Knob	レバーツマミ	
10	42:00:00 CB:06:87:20	Switch Apron 15 x 29	SWエプロン	
11	42:00:00 CB:06:87:30	-do.- 15 x 42	"	
12	32:00:00 CB:06:85:80	Switch Bush	SW用ブッシュ	
13	42:00:00 EZ:00:04:10	Hexagonal Set Screw M3 x 14	六角セットネジ M3 x 14	
14	42:00:00 EZ:00:04:20	-do.- M3 x 6	M3 x 6	
15	32:00:00 AA:08:44:10	Joint Holder	ジョイントホルダー	
16	32:00:00 NB:07:78:50	Sub Shassis	サブシャーシユニット R. C. A. E. B	
16	32:00:00 NB:07:78:60	-do.-	" U	
-A	42:00:00 CB:07:81:50	Safeguard Tape	保護テープ	
17	42:00:00 KA:20:03:90	Power Switch	電源SW U. C. A	
17	42:00:00 KA:20:04:00	-do.-	" E. B	
17	42:00:00 FZ:00:01:10	Spark Killer Cap.	スパークキラーコン U. E	
17	42:00:00 FZ:00:09:50	-do.-	" C	
18	32:00:00 CB:07:81:10	Lense (Lamp)	ランプレンズ	
19	32:00:00 CB:07:81:20	Collar Plate	カラープレート	
20	32:00:00 AA:08:34:90	Holder (Lamp)	レンズホルダー	
21	32:00:00 NA:06:83:80	Lamp C.B	ランプシート	
-A	42:00:00 JB:00:03:10	Pilot Lamp 12V 60mA	ランプ	
22	42:00:00 CB:06:88:80	Plastic Rivet	プラスチックリベット 3 x 5	
23	42:00:00 LB:30:04:80	Head-phone Jack	ヘッドホンジャック	
24	42:00:00 KA:50:08:80	Rotaly Switch (Speaker)	SP切換SW	
25	32:00:00 AA:08:34:70	Switch Stay	SWステイ	
26	32:00:00 NA:06:82:60	Tone Control C.B	トーンコン・シート U	
26	32:00:00 NA:06:82:70	-do.-	" R. C. E. A	
-A	42:00:00 HY:00:05:50	Variable Resistor (Vol. Control)	メインVR	
-B	42:00:00 KA:20:05:70	Lever Switch	レバースW	
-C	42:00:00 HY:00:05:70	Variable Resistor	TREBLE トーンVR	
-D	42:00:00 KA:20:05:50	Lever Switch	レバースW	
-E	42:00:00 HY:00:05:60	Variable Resistor	BASS トーンVR	
-F	42:00:00 KA:20:05:40	Lever Switch	レバースW	
-G	42:00:00 KA:20:05:80	-do.-	"	
27	32:00:00 AA:08:57:90	Switch Stay	延長シャフトユニット	
28	32:00:00 CB:07:80:40	Push Button Silver	プッシュボタン	
29	32:00:00 NA:06:83:60	Metar C.B	メーターシート	

For Service Manuals Contact
MAURITRON TECHNICAL SERVICES
8 Cherry Tree Rd, Chinnor
Oxon OX9 4QY
Tel:- 01844-351694 Fax:- 01844-352554
Email:- enquiries@maurtron.co.uk

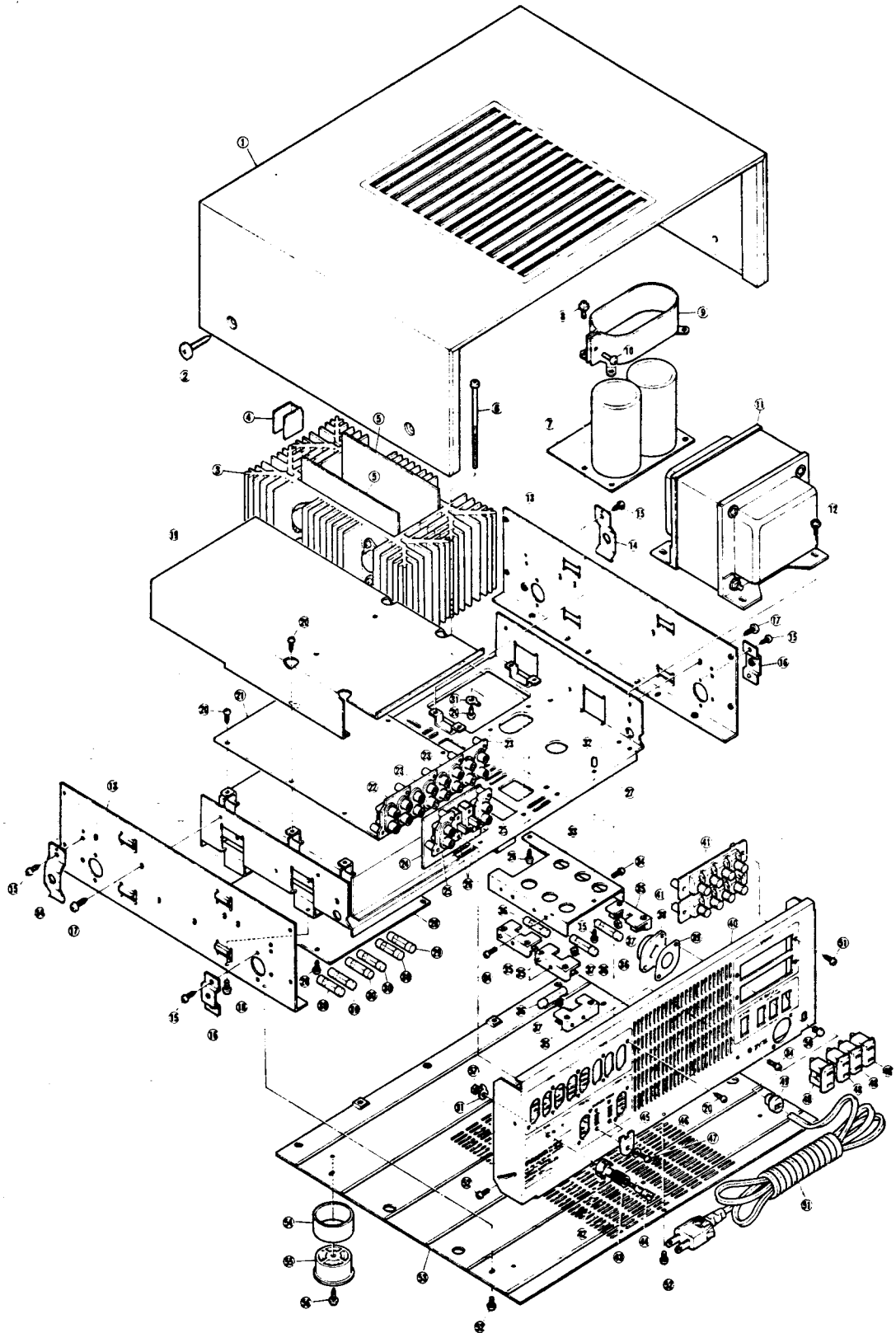

UL & CSA MODEL

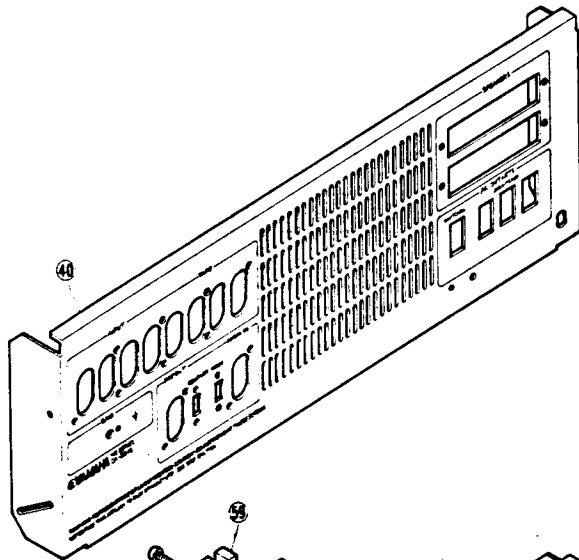

AUSTRALIAN MODEL

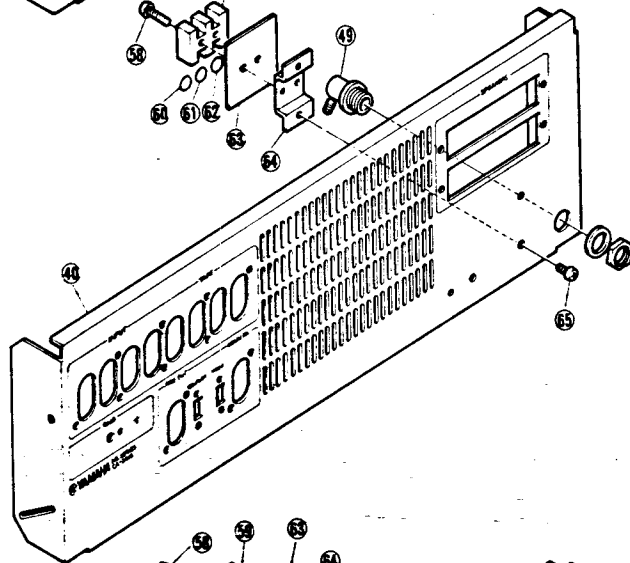

EUROPEAN & B.S MODEL

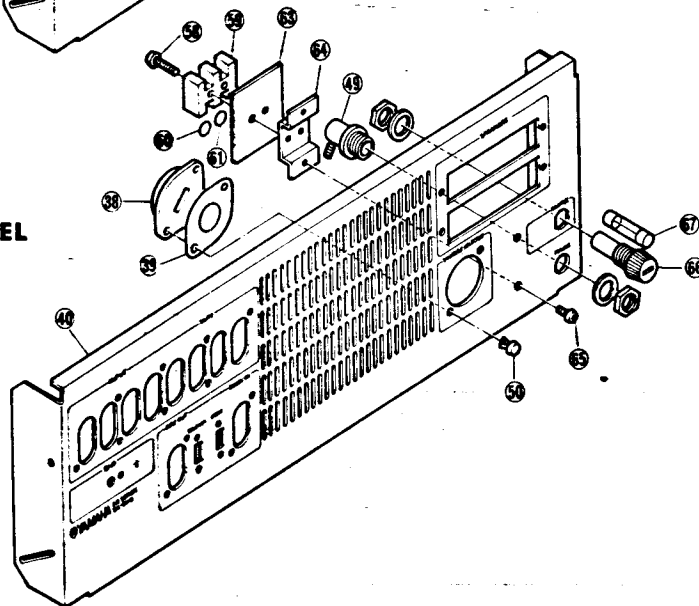

Ref. No.	Part No.	Description	Remarks	Common Models
1	32:00:00:86:61:42:20	Cabinet	外 蓋 R. A. E. B	
1	32:00:00:86:61:42:30	-do.-	・ U. C	
2	32:00:00:AA:03:32:60	Cabinet Fixing Screw	止 メ ネ ジ	
3	32:00:00:BA:06:79:70	Heat Sink	放 熱 器	
4	32:00:00:BA:06:91:40	-do.-	・	
5	32:00:00:NA:06:84:30	Main C.B	メ イン シ ー ト U	
5	32:00:00:NA:06:84:40	-do.-	・ J. R. C. A. E. B	
6	42:00:00:EZ:00:02:90	Pan Head Screw M5 x 120	な べ 小 ネ ジ M 5 x 120	FCM3-BI
7	32:00:00:NA:06:83:70	Electrolytic Cap. C.B	ケ ミ コ ン シ ー ト	
8	42:00:00:EZ:00:02:60	BW Head Tapping Screw M3 x 8	BWヘッドタッピングネジ M 3 x 8	ZMC2-BI
9	32:00:00:AA:08:57:20	Band Electrolytic Cap.	ケ ミ コ ン バ ン ド	
10	42:00:00:EC:40:10:20	Binding Head Screw M4 x 10	バ イ ン ド 小 ね じ M4 x 10	FCM3-BI
11	42:00:00:GA:60:92:10	Power Transformer	電 源 ト ラ ン ス	U. C
11	42:00:00:GA:60:92:20	-do.-	・ R. A. E. B	
12	42:00:00:EZ:00:03:90	BW Head Tapping Screw M4 x 8	BWヘッド小ネジ M 4 x 8	FCM3-BI
13	32:00:00:AA:08:57:10	Side Frame	サ イ ド フ レ ー ム	
14	32:00:00:AA:08:57:70	Spring Metal	ス プ リ ン グ 金 具	
15	42:00:00:EI:33:00:60	Bind Tapping Screw M3 x 6	バ イ ン ド タ ッ ピ ン ね じ M 3 x 6	FCM3-BI
16	32:00:00:AA:08:57:80	Case Stay	ケ ー ス ス テ ー	
17	42:00:00:EI:34:00:80	Bind Tapping Screw M4 x 8	バ イ ン ド タ ッ ピ ン ね じ M 4 x 8	FCM3-BI
18	42:00:00:ED:34:00:80	Binding Head Screw M4 x 8	バ イ ン ド 小 ね じ M4 x 8	FCM3-BI
19	32:00:00:AA:08:33:30	Switch Cover	シ ー ル ド ケ ー ス	
20	42:00:00:EI:33:00:80	Binding Head Screw M3 x 8	バ イ ン ド タ ッ ピ ン ね じ M 3 x 8	FCM3-BI
21	32:00:00:NA:06:83:20	Function C.B	フ ン ク シ ョ ン シ ー ト	U
21	32:00:00:NA:06:83:30	-do.-	・ R. C. A. E. B	
22	42:00:00:LB:40:03:40	Pin Jack PC4PL	ピ ン ジ ャ ッ ク P C 4 P L 型 改 装	
23	40:00:00:LB:40:03:10	-do.- L-Type	・	
24	32:00:00:NA:06:84:20	Coupler C.B	カ プ ラ ー シ ー ト	
25	42:00:00:LB:20:09:60	Pin Jack 2P	ピ ン ジ ャ ッ ク 2 P	
26	42:00:00:KA:40:02:10	Slide Switch	ス ラ イ ド S W	
27	32:00:00:AA:08:57:00	Main Chassis	メ イン シ ャ ー シ	
28	32:00:00:NA:06:87:80	Power Supply C.B	電 源 シ ー ト J. R. A	
28	32:00:00:NA:06:87:90	-do.-	・ U. C	
28	32:00:00:NA:06:88:00	-do.-	・ E. B	
29	42:00:00:NB:00:03:10	Fuse 0.5AT 250V	ヒ ュ ー ズ R. A	
29	42:00:00:KB:00:07:10	-do.- 500mAT 250V S	・ B. E	
29	42:00:00:KB:00:10:10	-do.- 0.5A 250V UL	・ U. C	
30	42:00:00:KB:00:03:30	-do.- 1.0AT 250V	・ R. A	
30	42:00:00:KB:00:07:30	-do.- 1.0AT 250V S	・ B. E	
30	42:00:00:LB:00:10:20	-do.- 1.0AT 250V UL	・ U. C	
31	42:00:00:LA:00:02:80	Lug Terminal M3	ア ー ス ラ グ	
32	42:00:00:CB:07:82:50	Screw Cover	ビ ス カ バ ー	
33	32:00:00:AA:08:57:60	Fuse Stay	ヒ ュ ー ズ ス テ ー	
34	42:00:00:ED:33:00:80	Binding Head Screw M3 x 8	バ イ ン ド 小 ね じ M3 x 8	FCM3-BI
35	42:00:00:LB:20:08:40	Fuse Holder	ヒ ュ ー ズ ホ ル ダ ー	R. U. C. A. J
35	42:00:00:LB:20:09:40	-do.-	・ E. B	
36	42:00:00:KB:00:01:80	Fuse 10A 125V	ヒ ュ ー ズ R. A. J	
36	42:00:00:KB:00:13:90	-do.- -do.-	U L タ イ ム ラ グ U. C	
36	42:00:00:KB:00:07:70	-do.- -do.-	Ⓢ タ イ ム ラ グ E. B	

Ref. No.	Part No.	Description	Remarks	Common Models
37	42:00:00 EV:10:33:00	Hexagonal Nut M3		
38	42:00:00 LB:20:02:60	Voltage Selector	電圧切換器 R. E. B	
39	32:00:00 CB:07:64:00	Isolation Plate for Voltage Selector	V S 絶縁板	
40	32:00:00 NB:07:79:40	Rear Panel	リアパネルユニット R	
40	32:00:00 NB:07:79:50	-do.-	~ U	
40	32:00:00 NB:07:79:60	-do.-	~ A	
40	32:00:00 NB:07:79:70	-do.-	~ E. B	
40	32:00:00 NB:07:90:40	-do.-	~ C	
41	42:00:00 LA:00:18:42	Speaker Terminal 4P	4Pスピーカーターミナル	
42	32:00:00 CB:07:81:70	Saucer	受皿	
43	32:00:00 BB:05:48:20	Hand Clip	ハンドグリップ	
44	32:00:00 BB:05:48:10	GND Bolt	G N D ボルト	
45	32:00:00 CB:05:86:80	Coupler Stopper	カブラーストッパー	
46	42:00:00 EV:20:33:00	Plain Washer M3	平皿金ミガキ丸M3	
47	42:00:00 EC:32:60:40	Truss Head Screw M2.6 x 4	トラス小ネジ M 2.6 × 4	
48	42:00:00 LB:20:07:10	A.C Socket Spring Type	A C コンセント J. R. U. C	
49	42:00:00 CB:06:86:30	Cord Stopper	コードストッパー R. U. C	
50	32:00:00 CB:06:88:80	Plastic Rivet	プラスチックリベット	
51	42:00:00 MC:00:03:40	A.C Cord SPT-1, POT-64	電源コード R. U. C	
51	42:00:00 MG:00:05:00	-do.- SA-1	~ A	
51	42:00:00 MG:00:04:60	-do.- VM0077	~ E	
52	42:00:00 ED:33:00:60	Binding Head Screw M3 x 6	バインド小ネジ M 3 × 6 FCM3-BI	
53	32:00:00 AA:08:33:20	Bottom Cover	ボトムカバー	
54	32:00:00 BA:06:86:40	Ring	リング	
55	32:00:00 CB:07:79:50	Leg	脚	
56	42:00:00 EI:03:00:80	Binding Head Screw M3 x 8	バインドタッピン M 3 × 8 ZMC2-Y	
57	42:00:00 EV:10:13:00	Hexagonal Nut M3	六角ナット M3	
58	42:00:00 ED:03:01:60	Binding Head Screw M3 x 16	バインド小ネジ ZMC2-Y, B. A. E	
59	42:00:00 LA:00:10:40	Connection Terminal 3P	3 P 中継端子台	
60	42:00:00 CA:06:06:80	Mark Charge	充電マーク	
61	42:00:00 CA:06:06:70	-do.- Neutral	中立マーク	
62	42:00:00 CA:06:06:90	-do.- Earth	アースマーク	
63	32:00:00 CB:07:49:70	Isolation Plate	絶縁板	
64	32:00:00 AA:08:20:10	Stay for Connection Terminal	端子ステイ	
65	42:00:00 EI:03:00:00	Binding Head Screw M3 x 6	バインド小ネジ FCM3-BI	
66	42:00:00 LB:20:05:90	Fuse Holder	ヒューズホルダー	
67	42:00:00 KB:00:07:90	Fuse Time Lug 4.0AT 250V	ヒューズ	

Ref. No.	Part No.	Description	Remarks	Common Models
	32:00:00 NA:06:82:30	Power Supply C.B	電源シート	U.C
	32:00:00 NA:06:82:40	-do.-	"	E.B
	32:00:00 NA:06:82:50	-do.-	"	J.R.A
	42:00:00 FJ:23:81:00	Electrolytic Cap.	ケミコン タテ	100/16
	42:00:00 FJ:14:82:20	-do.-	"	220/25
	42:00:00 FJ:17:83:30	-do.-	"	330/63
	42:00:00 FJ:28:74:70	-do.-	"	47/80
	42:00:00 FJ:29:82:20	-do.-	"	220/100
	42:00:00 FM:09:62:20	Bipolar Electrolytic Cap.	ケミコン (B-P)	2.2/16
	42:00:00 FM:11:71:00	-do.-	"	10/50
	42:00:00 FM:39:81:00	-do.-	"	100/16
	42:00:00 FM:40:71:00	-do.-	"	10/25
		For Service Manuals Contact MAURITRON TECHNICAL SERVICES 8 Cherry Tree Rd, Chinnor Oxon OX9 4QY Tel: 01844-351694 Fax: 01844-352554 Email: enquiries@mauritron.co.uk		
	42:00:00 FZ:00:06:80	Metalized Film Resistor	金属被膜抵抗	0.1/250
	42:00:00 GD:90:00:50	Air Core Coil	空心コイル	3μH
	42:00:00 HL:42:41:00	Metal Oxide Resistor	酸化抵抗	2P 10Ω
	42:00:00 HL:42:62:70	-do.-	"	2P 2.7K
	42:00:00 HL:43:52:70	-do.-	"	3P 270Ω
	42:00:00 HZ:00:07:10	Incombustible Resistor	不燃性抵抗	1P 4.7Ω
	42:00:00 IA:08:44:00	Transistor 2SA844	トランジスタ	
	42:00:00 IA:08:72:00	-do.- 2SA872	"	
	42:00:00 IB:05:36:00	-do.- 2SB536	"	
	42:00:00 IB:05:66:00	-do.- 2SB566ANS	"	(B, C, D)
	42:00:00 ID:05:26:30	-do.- 2SD526	"	(O~Y)
	42:00:00 IC:12:13:30	-do.- 2SC1213A	"	(C, D)
	42:00:00 IC:17:75:00	-do.- 2SC1775	"	
	42:00:00 IC:19:18:00	-do.- 2SC1918	"	(E~G)
	42:00:00 ID:03:81:00	-do.- 2SD381	"	
	42:00:00 ID:04:76:00	-do.- 2SD476ANS	"	(B~D)
	42:00:00 IF:00:00:40	Diode 1S1555	ダイオード	
	42:00:00 IH:00:04:20	-do.- 1S1885	"	
	42:00:00 IH:00:03:30	-do.- 1S1887	"	
	42:00:00 IH:00:04:70	-do.- 1D4B1	"	
	42:00:00 IF:00:05:70	Zener Diode HZ-06C	ツェナーダイオード	
	42:00:00 KB:00:03:10	Fuse Withstand Current 0.5AT 250V	ヒューズ	J.R.A
	42:00:00 KB:00:07:10	-do.- S Time Lug 500mAT 250V	"	E.B
	42:00:00 KB:00:10:10	-do.- UL 0.5A 250V	"	U.C
	42:00:00 KB:00:03:30	-do.- Withstand Current 1.0AT 250V	"	J.R.A
	42:00:00 KB:00:07:30	-do.- S Time Lug 1.0AT 250V	"	E.B
	42:00:00 KB:00:10:20	-do.- UL 1.0A 250V	"	U.C
	32:00:00 BA:06:91:40	Heat Sink	放熱器	

Ref. No.	Part No.	Description	Remarks	Common Models
	42:00:00:KC:00:03:10	Relay	リ レ -	
		Binding Head Screw M3 x 8	バインド小ネジ	FMN3-3m
		Hexagonal Nut M3	六角ナット	
	32:00:00:NA:06:84:30	Main C.B	メインシート	U
	32:00:00:NA:06:84:40	-do.-	"	J. R. C. A. E. B
	42:00:00:FH:61:12:20	Ceramic Cap. 100P/500	セラコン	
	42:00:00:FH:61:16:80	-do.- 68P/500	"	
	42:00:00:FH:61:14:70	-do.- 47P/500	"	
	42:00:00:FJ:18:61:00	Electrolytic Cap.	ケミコンタテ	1/80
	42:00:00:FZ:00:06:80	Metalized Milar Cap.	メタライズドマイラ-C	0.047/400
		Metal Film Resistor	金属被膜抵抗	240Ω
	42:00:00:HL:41:44:70	Metal Oxide Resistor	酸化抵抗	1P 47Ω
	42:00:00:HL:41:48:20	-do.-	"	1P 82Ω
	42:00:00:HL:41:66:80	-do.-	"	1P 6.8K
	42:00:00:HL:41:71:20	-do.-	"	1P 12K
	42:00:00:HM:55:24:70	Cement and Ceramic Mold Resistor	セメント抵抗	5P 0.47Ω
	42:00:00:HM:55:41:00	-do.-	"	5P 10Ω
	42:00:00:HY:00:03:80	Metal Glaze V. R	メタルグレースVR	CR29R, B-2.2K
	42:00:00:HW:19:44:70	Fuse Resistor 70mA 47Ω	ヒューズ抵抗	J. R. C. B. A. E
	42:00:00:HW:29:44:70	-do.- -do.-	"	U
	42:00:00:HW:10:46:80	-do.- 85mA 68Ω	"	J. R. C. B. A. E
	42:00:00:HW:20:46:80	-do.- -do.-	"	U
	42:00:00:HW:19:51:00	-do.- 50mA 100Ω	"	J. R. C. B. A. E
	42:00:00:HW:29:51:00	-do.- -do.-	"	U
	42:00:00:HW:19:53:90	-do.- 25mA 390Ω	"	J. R. C. B. A. E
	42:00:00:HW:29:53:90	-do.- -do.-	"	U
	42:00:00:HW:19:34:70	-do.- 230mA 4.7Ω	"	J. R. C. B. A. E
	42:00:00:HW:29:34:70	-do.- -do.-	"	U
	42:00:00:HZ:00:07:10	Incombustible Resistor	不燃性抵抗	1P 4.7Ω
	42:00:00:IA:06:73:10	Transistor 2SA673A	トランジスタ	(C. D)
	42:00:00:IA:07:45:30	-do.- 2SA745B	"	(O ~ Y) 140V > Vcbo
	42:00:00:IA:08:72:20	-do.- 2SA872	"	BV
	42:00:00:IB:05:37:10	-do.- 2SB537	"	150V > Vcbo
	42:00:00:IC:12:13:30	-do.- 2SC1213A	"	(C. D)
	42:00:00:IC:14:03:30	-do.- 2SC1403B	"	(O ~ Y) 140V > Vcbo
	42:00:00:IC:17:75:00	-do.- 2SC1775	"	

Ref. No.	Part No.	Description	Remarks	Common Models
	42:00:00:IC:17:75:20	Transistor -do.-	トランジスタ BV	
	42:00:00:ID:03:82:10	-do.- 2SD382	150V > Vcbo	
	32:00:00:IE:10:07:70	FET 2SK99A	F E T	
	42:00:00:IF:00:00:40	Diode 1S1555	ダイオード	
	42:00:00:IF:00:07:50	-do.- 1S2462		
	42:00:00:IH:00:02:40	-do.- 1S1885		
	42:00:00:IF:00:05:70	Zener Diode HZ6C	ツェナーダイオード	
	42:00:00:IF:00:02:80	-do.- WZ210		
	32:00:00:BA:06:79:70	Heat Sink	放熱板	
	32:00:00:BB:06:30:80	Pusher for Transistor	Tr プッシャー	
	42:00:00:IL:00:02:30	Base for Transistor	マイカベース AC201	
	42:00:00:LB:30:02:70	Socket for Transistor	Tr ソケット	
		Binding Head Screw M3 x 8	バインド小ネジ FNM3-3m	
		Hexagonal Nut M3	六角ナット BNM1-3m	
	32:00:00:NA:06:83:20	Function C.B	ファンクションシート U	
	32:00:00:NA:06:83:30	-do.-	R. C. A. E. B	
	42:00:00:FD:11:23:90	Polystyrene Capacitor	スチコン 390P/50	
	42:00:00:FJ:21:91:00	Electrolytic Capacitor	ケミコンタテ 1000/6.3	
	42:00:00:FJ:14:81:00	-do.-	100/25	
	42:00:00:FZ:00:10:40	Tantalum Capacitor	タンタルコンデンサ 100/6.3	
	42:00:00:FD:12:81:00	-do.-	100/10	
	42:00:00:FZ:00:07:20	UPF Capacitor	UPFコンデンサ 0.015/50	
	42:00:00:FZ:00:07:30	-do.-	0.056/50	
	42:00:00:HT:41:00:10	Solid Type VR.	ソリッドVR #10 B-220Ω	
	42:00:00:HU:87:64:70	Metal Film Resistor	金属被膜抵抗 4.7K	
	42:00:00:HU:87:75:60	-do.-	56K	
	42:00:00:HW:19:43:30	Fuse Resistor 85mA 33Ω	ヒューズ抵抗 R. C. B. A. E	
	42:00:00:HW:29:43:30	-do.- -do.-	U	
	42:00:00:HW:19:53:90	-do.- 25mA 390Ω	R. C. B. A. E	
	42:00:00:HW:29:53:90	-do.- -do.-	U	
	42:00:00:IA:06:73:10	Transistor 2SA673A	トランジスタ (C. D)	
	42:00:00:IA:07:77:30	-do.- 2SA777	(Q. R)	
	42:00:00:IA:08:72:00	-do.- 2SA872		
	42:00:00:IC:15:09:30	-do.- 2SC1509	(Q. R)	

Ref. No.	Part No.	Description	Remarks	Common Models
42 00 00	I C 17 75 00	Transistor 2SC1775	*	
32 00 00	I E 10 06 00	Dual FET 2SK100	F E T	
42 00 00	I F 00 05 30	HV46R	バリスタ	
42 00 00	I F 00 07 70	VD1212	*	
42 00 00	I G 00 13 50	I.C #00135	I C	
42 00 00	I H 00 02 40	Diode 1S1885	ダイオード	
42 00 00	K C 00 03 00	Lead Relay RL6442-H132	リードリレー	
32 00 00	N A 06 82 60	Tone Control C.B	トーンコンシート	U
32 00 00	N A 06 82 70	-do.-	*	R. C. A. E. B
42 00 00	F D 11 23 90	Polystyren Capacitor 390P/50	スチコンタテ	
42 00 00	F D 11 28 20	-do.- 820P/50	*	
42 00 00	H L 41 53 90	Metal Oxide Resistor	酸化抵抗	1P 390Ω
42 00 00	H W 19 43 30	Fuse Resistor 85mA 33Ω	ヒューズ抵抗	R. C. B. A. E
42 00 00	H W 29 43 30	-do.- -do.-	*	U
42 00 00	H W 19 44 70	-do.- 70mA 47Ω		
42 00 00	H W 29 44 70	-do.- -do.-		
42 00 00	I A 06 73 10	Transistor 2SA673A	トランジスタ	(C. D)
42 00 00	I A 08 72 00	-do.- 2SA872	*	
42 00 00	I C 17 75 00	-do.- 2SC1775	*	
42 00 00	I E 10 05 50	FET 2SK68A	F E T	L2, M1, M2, N1
42 00 00	I F 00 05 30	Varistor HV46R	バリスタ	
42 00 00	I F 00 07 70	" VD1212	*	
42 00 00	I H 00 02 40	Diode 1S1885	ダイオード	
42 00 00	K C 00 03 00	Lead Relay RL6442H132	リードリレー	
32 00 00	N A 06 83 60	Meter C.B	メーターシート	
42 00 00	H L 41 61 00	Metal Oxide Resistor	酸化抵抗	1P, 1K
42 00 00	H T 41 00 90	Solid Type VR 10φ B-4.7K	ソリッドVRヨコ型	
42 00 00	I E 00 00 20	FET 2SK30A GR	F E T	
42 00 00	I F 00 05 50	Zener Diode HZ12C	ツェナーダイオード	
42 00 00	I G 00 13 60	I.C PM-02	I C	
32 00 00	N A 06 83 70	Electrolytic Cap. C.B	ケミコンシート	

For Service Manuals Contact
MAURITRON TECHNICAL SERVICES
 8 Cherry Tree Rd, Chinnor
 Oxon OX9 4QY
 Tel: 01844 351694 Fax: 01844 352554
 Email: enquiries@mauriron.co.uk

